



OPERATING INSTRUCTIONS

EN

Translation of the original instructions

DUO 125, DUO 125 M

Rotary Vane Pump

PFEIFFER  **VACUUM**



蒙天真空
MT VACUUM

Table of contents

| | | |
|-----------|--|-----------|
| 1 | About this manual | 3 |
| 1.1 | Validity | 3 |
| 1.2 | Conventions | 3 |
| 2 | Safety | 5 |
| 2.1 | Safety precautions | 5 |
| 2.2 | Protective equipment | 5 |
| 2.3 | Proper use | 6 |
| 2.4 | Improper use | 6 |
| 3 | Transport and storage | 7 |
| 3.1 | Transport | 7 |
| 3.2 | Storage | 7 |
| 4 | Product description | 8 |
| 4.1 | Product identification | 8 |
| 4.2 | Function | 9 |
| 5 | Installation | 10 |
| 5.1 | Setting up the pump | 10 |
| 5.2 | Connecting the vacuum side | 10 |
| 5.3 | Connecting the exhaust side | 11 |
| 5.4 | Connecting to the mains power supply | 11 |
| 5.5 | Filling up the operating fluid | 14 |
| 5.6 | Operations monitoring (Option) | 15 |
| 6 | Operation | 16 |
| 6.1 | Before switching on the pump | 16 |
| 6.2 | Switching on the pump | 16 |
| 6.3 | Pumping condensable vapours | 17 |
| 6.4 | Topping up the operating fluid | 19 |
| 6.5 | Switching off the pump | 20 |
| 7 | Maintenance | 21 |
| 7.1 | Precautions | 21 |
| 7.2 | Changing the operating fluid | 23 |
| 7.3 | Changing the kind of operating fluid | 25 |
| 7.4 | Cleaning and re-setting the silencer | 26 |
| 7.5 | Changing the gas ballast filter | 27 |
| 7.6 | Assembling the motor and coupling | 28 |
| 8 | Decommissioning | 30 |
| 8.1 | Shutting down for longer periods | 30 |
| 8.2 | Re-starting | 30 |
| 8.3 | Disposal | 30 |
| 9 | Malfunctions | 31 |
| 9.1 | Rectifying malfunctions | 31 |
| 10 | Service | 33 |
| 11 | Spare parts | 34 |
| 11.1 | Spare parts packages | 34 |
| 12 | Accessories | 39 |
| 13 | Technical data | 40 |
| 13.1 | General | 40 |
| 13.2 | Technical data | 41 |



13.3 Dimensions 42
Declaration of conformity 43

1 About this manual

1.1 Validity

This operating manual is for customers of Pfeiffer Vacuum. It describes the functioning of the designated product and provides the most important information for safe use of the unit. The description follows applicable EU guidelines. All information provided in this operating manual refers to the current state of the product's development. The documentation remains valid as long as the customer does not make any changes to the product. Up-to-date operating instructions can also be downloaded from www.pfeiffer-vacuum.com.

Applicable documents

| DUO 125 | Operating instructions |
|---|---------------------------|
| Declaration of Conformity | Part of this document |
| Operating instructions for accessories (order-specifically) | see section "accessories" |

*also available via www.pfeiffer-vacuum.com

1.2 Conventions

Safety instructions

The safety instructions in Pfeiffer Vacuum operating instructions are the result of risk evaluations and hazard analyses and are oriented on international certification standards as specified by UL, CSA, ANSI Z-535, SEMI S1, ISO 3864 and DIN 4844. In this document, the following hazard levels and information are considered:

| |
|---|
| DANGER |
| <p>Imminent danger Indicates an imminent hazardous situation that will result in death or serious injury.</p> |
| WARNING |
| <p>Possibly imminent danger Indicates an imminent hazardous situation that can result in death or serious injury.</p> |
| CAUTION |
| <p>Possibly imminent danger Indicates an imminent hazardous situation that can result in minor or moderate injury.</p> |
| NOTICE |
| <p>Command or note Command to perform an action or information about properties, the disregarding of which may result in damage to the product.</p> |

Pictographs



Prohibition of an action to avoid any risk of accidents, the disregarding of which may result in serious accidents



Warning of a displayed source of danger in connection with operation of the unit or equipment



Command to perform an action or task associated with a source of danger, the disregarding of which may result in serious accidents



Important information about the product or this document

Instructions in the text

→ Work instruction: here you have to do something.

Symbols used

The following symbols are used consistently throughout in all illustrations:

- Ⓟ Vacuum flange
- Ⓛ Exhaust flange
- Ⓞ Gas ballast valve
- ⚡ Power connection



2 Safety

2.1 Safety precautions



Duty to inform

Each person involved in the installation, operation or maintenance of the vacuum pump must read and observe the safety-related parts of these operating instructions.

→ The operator is obligated to make operating personnel aware of dangers originating from the vacuum pump, the pumped medium and the entire system.



Installation and operation of accessories

Pfeiffer Vacuum pumps can be equipped with a series of adapted accessories. The installation, operation and maintenance of connected devices are described in detail in the operating instructions of the individual components.

→ For information on order numbers of components, see "Accessories".

→ Use original accessory parts only.

- Do not expose any body parts to the vacuum.
- Observe the safety and accident prevention regulations.
- Check regularly that all safety precautions are being complied with.
- Do not carry out any unauthorised modifications or conversions to the pumps.
- Depending on the operating and ambient conditions, the surface temperature of the pumps may rise above 70 °C. Use suitable finger guards if necessary.
- When returning the pumps to us please note the instructions in the Service section.

The following safety instructions are only valid for the disassembly of the drive system for a vacuum pump with a magnetic coupling:

- When disassembling the drive system from the pump housing, the strong magnetic field may influence the function and operational reliability of electrical and electronic devices.
- Persons with cardiac pacemakers must keep away from the magnetic coupling.

Danger to life!

– **Minimum distance: 2 m!**

- Disassembled magnetic couplings must be kept away from computers, data storage media and other electronic components.
- Keep the disassembled components of the magnetic coupling separate at all times. Danger of crushing!
- Do not allow any magnetised parts into the vicinity of the magnetic coupling. Danger of injury!

2.2 Protective equipment

Determined situations concerning the handling of vacuum pumps require wearing of personal protective equipment. The owner, respectively the employer are obligated to provide an adequate equipment to any operating persons.



DANGER

Danger to health by hazardous substances during maintenance or installation

Depending on the process vacuum pumps, components or operating fluids can be contaminated by toxic, reactive or radioactive substances.

→ Wear adequate protective equipment during maintenance and repairs or in case of reinstallation.





CAUTION

Risk of injury through hot surfaces

Vacuum pumps can become hot during operation.

- Allow the pump to cool before maintenance and repairs.
- If necessary wear protective gloves according to EN 420.

WARNING

Increased noise emission!

Increased noise emission can occur within a limited area surrounding the vacuum pump.

- Provide noise protection or
- wear hearing protection.

2.3 Proper use



NOTICE

EC conformity

The manufacturer's declaration of conformity becomes invalid if the operator modifies the original product or installs additional components.

- Following installation into a plant and before commissioning, the operator must check the entire system for compliance with the valid EU directives and reassess it accordingly.

- The vacuum pump may only be used to generate a vacuum.
- Only use the vacuum pump for applications with oxygen concentration $\leq 21\%$.
- Installation, operating and maintenance regulations must be complied with.
- Other accessories, than those described in this manual, must not be used without the agreement of Pfeiffer Vacuum.

2.4 Improper use

Improper use will cause all claims for liability and warranties to be forfeited. Improper use is defined as usage for purposes deviating from those mentioned above, especially:

- pumping of corrosive gases
- pumping of explosive media
- operation in potentially explosive areas
- pumping of gases containing impurities such as particles, dusts and condensate; note the vapour compatibility levels of the pump
- pumping of substances that tend to sublime
- use of the vacuum pump to generate pressure
- pumping of liquids
- the use of operating fluids not specified by Pfeiffer Vacuum
- connection to pumps or units which are not suitable for this purpose according to their operating instructions
- connection to units which have exposed voltage-carrying parts
- operation of the devices in areas with ionizing radiation



3 Transport and storage

3.1 Transport

Transport instructions

- Remove the locking cap from the vacuum and exhaust flange immediately before connecting!
 - Check the protective stainer, paying attention to the O-ring.
- Use only the crane eye on the top side of the pump to lift the pump.

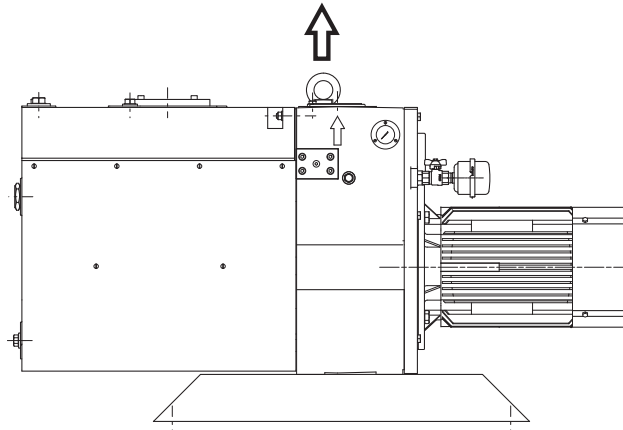

Fig. 1: Transporting the pump

3.2 Storage

- Check that all the openings on the pump are securely closed.
- Fill up the pump with new operating fluid to the top edge of the sight glass.
- Store the pump only indoors, preferably at temperatures between -10 °C and $+40\text{ °C}$.
 - In rooms with moist or aggressive atmospheres, the pump must be airproof shrink-wrapped in a plastic bag together with a bag of desiccant.
 - After storage periods longer than two years, it is recommended to carry out maintenance and change the operating fluid before using the pump.



4 Product description

4.1 Product identification

To correctly identify the product when communicating with Pfeiffer Vacuum, always have the information from the rating plate available and use it:

- Pump model and model number
- Serial number
- Type and amount of operating fluid
- Date of manufacture

Please find the voltage range and motor-related data on the separately attached motor rating plate.

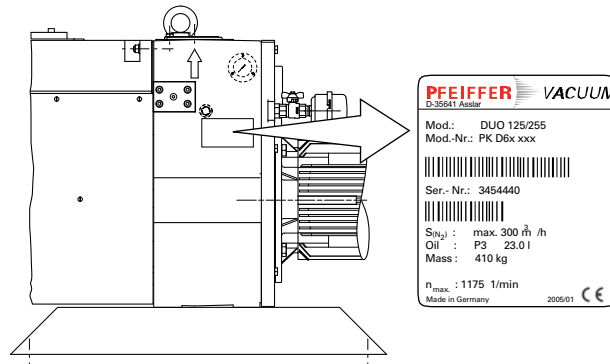

Fig. 2: Product identification on the rating plate

Scope of delivery

- Pump with motor/without motor
- Operating fluid (except F4 and F5)
- Cone strainer and centering ring with O-ring
- Locking cap for vacuum and exhaust flange
- Operating instructions

Pump types

| Pump type | Pump versions |
|-----------|--------------------------------|
| DUO 125 | Standard version of pump |
| DUO 125 M | Version with magnetic coupling |



4.2 Function

The vacuum pumps of the DUO-Line are dual stage rotary vane pumps and are used primarily for rough and medium vacuum applications. The pumps are fitted with a hydraulically controlled vacuum safety valve which, when the pump is at a stillstand, closes the vacuum chamber vacuum tight and at the same time vents the pump.

The version with magnetic coupling has as an alternative to conventional shaft feedthrough a static seal towards the outside.

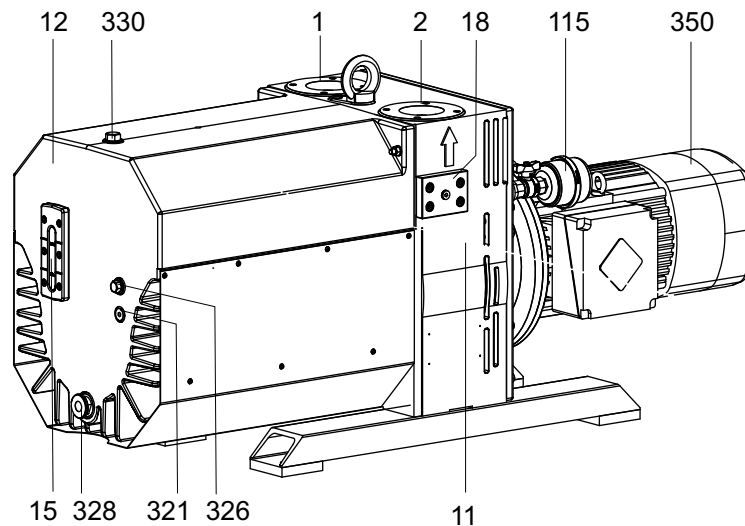

Fig. 3: DUO 125

| | | | |
|----|----------------|-----|---|
| 1 | Vacuum flange | 115 | Gas ballast valve |
| 2 | Exhaust flange | 321 | Connection temperature sensor |
| 11 | Support | 326 | Connection operating fluid level switch |
| 12 | Casing | 328 | Operating fluid drain screw |
| 15 | Sight glass | 330 | Operating fluid filler screw |
| 18 | Flange, OFM | 350 | Motor |



5 Installation

5.1 Setting up the pump

Installation location

Observe the following requirements when setting up the pump:

- Consider the load-bearing capacity of the installation site.
 - Maximum installation altitude 2000 m (above mean sea level)
 - Permissible ambient temperature: +12 ... 40 °C
 - Maximum relative humidity 85%
- Fill up with operating fluid before operating the first time (see p. 14, chap. 5.5).
- Amount and type according to rating plate
- Always place the pump on a firm, even surface.
- The base frame has four holes for anchoring onto the base.
- When installing the pump in a closed housing, ensure there is sufficient air circulation.
- Sight glass and gas ballast valve must be visible and readily accessible.
 - Voltage and frequency information given on the motor rating plate must be visible.

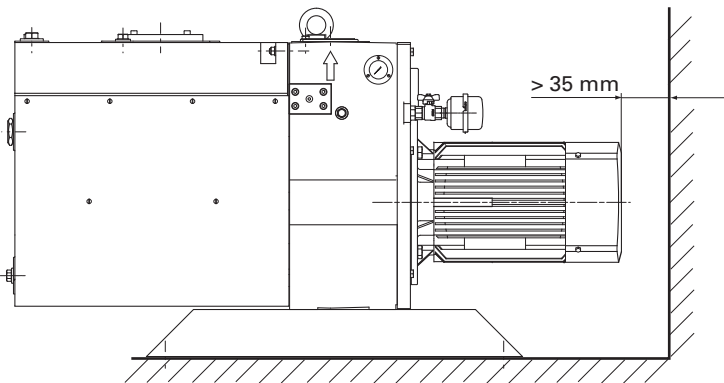

Fig. 4: Setting up the pump

5.2 Connecting the vacuum side

- Remove locking cap from the vacuum flange;
- pay attention to the cone strainer and the respective O-ring in the intake port.
- Clear welded lines of any welding scales, loose parts etc. before installation.
- The connection between the pump and the vacuum chamber should be kept as short as possible.
- Depending on the pump type, use metallic hoses or PVC hoses with flange connections.
 - Separators, filters etc. may be installed upstream to protect the pump (see accessories). However, please observe the loss of pumping capacity due to the conductivity of the accessories.



5.3 Connecting the exhaust side



CAUTION

High pressure in the exhaust line!

Danger of damage to the seals and danger of the pump bursting.

- Install the line without shut-off valves on the exhaust side.
- If there is danger of a build-up of excess pressure (> 1500 hPa abs.) in the lines, observe all official accident prevention safety regulations.
- If the exhaust gases are being extracted, the exhaust pressure must be at least 250 hPa greater than the pressure at the intake side.

- Choose the cross-section of the exhaust line to be at least the size of the nominal connection diameter of the vacuum pump's exhaust connection.
- Piping to the pump must be suspended or supported.
 - Physical forces from the piping system must not be allowed to act on vacuum pumps.
- Lay piping from the pump sloping downward so that no condensate can flow back into the pump; otherwise fit a condensate separator.
 - If an air trap is created in the system, then a device for draining condensation water must be provided at the lowest point.



WARNING

Emission of toxic substances from the exhaust!

Danger of poisoning from emitted gases or vapours, which can be detrimental to health and/or can pollute the environment, depending on the particular application.

- Comply with the applicable regulations when working with toxic substances.
- Only officially approved filter systems may be used to separate and remove these substances.

5.4 Connecting to the mains power supply

Depending on the pump type, different motor versions or mains voltages are possible:

- Three phase motor (with 3 PTC) without switch and mains cable.



DANGER

Voltage-bearing elements

Danger to life from electric shock.

- The electrical connection can be carried out only by trained and authorised electricians.
- Disconnect the power supply and secure it against being switched back on.
- Ensure the system is adequately earthed.

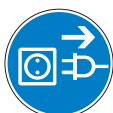

NOTICE

Excess voltage!

Danger of destroying the motor.

- Power connections must comply with local regulations. Voltage and frequency information given on the motor rating plate must correspond to the mains voltage and frequency values.
- To protect the motor and supply cable in case of malfunction, mains fuse protection must be implemented. Recommended: Type K slow blow circuit breaker.



Three-phase motor

The three-phase current motor circuit

The connections U1 - L2, V1 - L1 and W1 - L3 result in a clockwise rotation of the motor shaft as seen looking towards the motor fan.

Delta Connection

The three coils are connected in series with the connection point connected to the mains. The voltage of each coil is the same as the mains voltage whereas the mains current is the cube root of the coil current. Delta connections are denoted by the symbol Δ . The voltage between the mains supply lines is called mains voltage. The mains current is the current which flows in the supply lines.

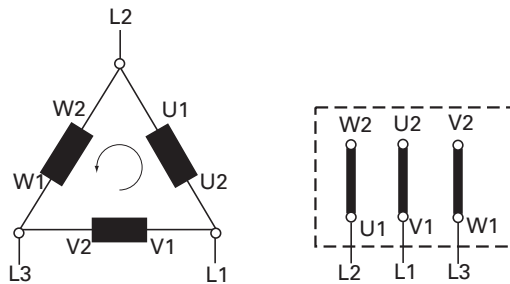

Fig. 5: Motor coil and connecting plate of Delta Connection (for low voltage)

Star Connection

The ends of the three coils are connected at the star center. The terminal voltage is the cube root of the coil voltage; the mains and the coil current are the same. Star connections are denoted by the symbol Y .

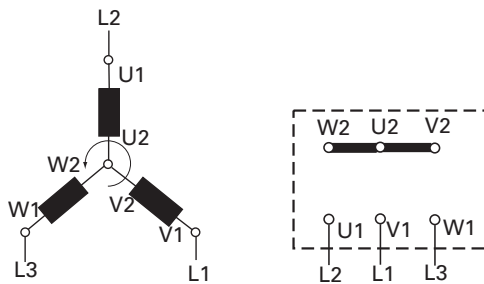

Fig. 6: Motor coil and connecting plate of Star Connection (for high voltage)



NOTICE

Do not start with star/delta connection.

→ Always start motor directly.

Inspection of the direction of rotation

For pumps with three-phase motors, it is necessary to check the direction of rotation!



CAUTION

Operating fluids may leak out!

If the direction of rotation is incorrect, there is a danger that operating fluids may leak at the vacuum flange.

→ Always check the direction of rotation before filling in operating fluid.

→ Remove the locking cap from the exhaust flange (if existing).

→ Switch the pump on briefly (from 2 to 3 sec.).

– The motor and motor fan must turn in a clockwise direction (see the arrow on the support stand).

→ If the direction of rotation is incorrect: Swap two phase contacts at the connecting cable.



→ Fill up the operating fluid.

Motor protection

With PTC temperature sensors (3PTC)

Pump motors equipped with PTC temperature sensors (3PTC) in the stator windings can be connected to a PTC resistor tripping device for protection against overload. Other approved motor temperature monitoring can be used also by the operator.

Tripping devices store the shutdown event and need to be manually switched back on again via the integrated RESET button or via the external RESET S3. Mains-ON is detected as an automatic RESET.

→ Set up the connections so that the directional rotation indicated on the pump is maintained, regardless of the representations in the current flow diagram.

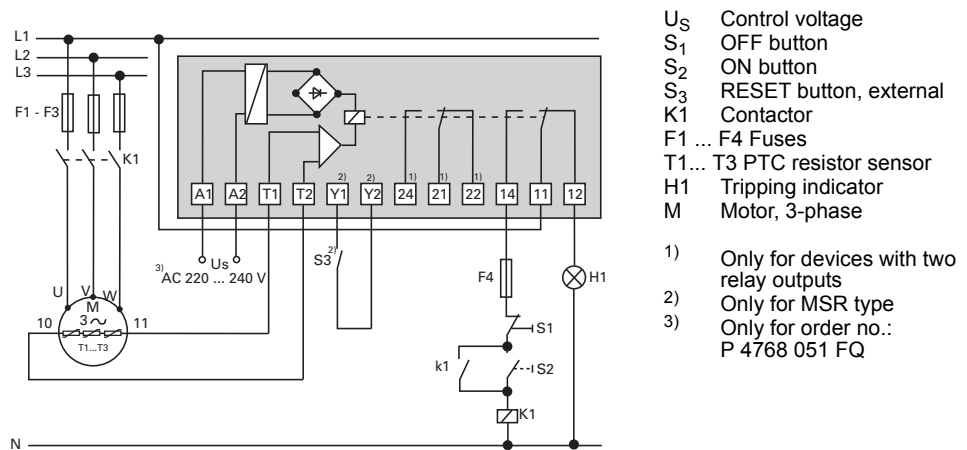

Fig. 7: Connection example for a three-phase AC motor with PTC resistor tripping device

Motor control system

Frequency converter (valid for three phase motors)

Operation of rotary vane pumps with variable rotation speeds is possible in the mains frequency range between 35 and 60 Hz. The start-up can use a ramp (run-up time: max. 30 s); the shutdown can occur directly.

5.5 Filling up the operating fluid

The type and amount of operating fluid should be visible on the pump's rating plate for every rotary vane pump.

The delivery consignment for the **standard pump** contains sufficient operating fluid for one filling. The use of other operating fluids requires prior authorisation from Pfeiffer Vacuum.

Permissible operating fluids

- P3 (Standard operating fluid)
- D1 for special applications (e.g. higher operating temperatures)
 - Ultimate pressure measured with gas type dependent gauge: $< 5 \cdot 10^{-2}$ hPa



NOTICE

Use approved operating fluids only!

The use of operating fluids that have not been approved by Pfeiffer Vacuum shall result in a limited warranty. In such cases, it is not possible to guarantee that product-specific performance data will be achieved.

→ Prior consultation is required before using other application-specific operating fluids.

Filling up the operating fluid

- Unscrew operating fluid filler screw 330.
- Fill up the operating fluid.
 - First fill when the pump is cold: Maximum 3/4 of the min./max. range.
- Screw in operating fluid filler screw 330.

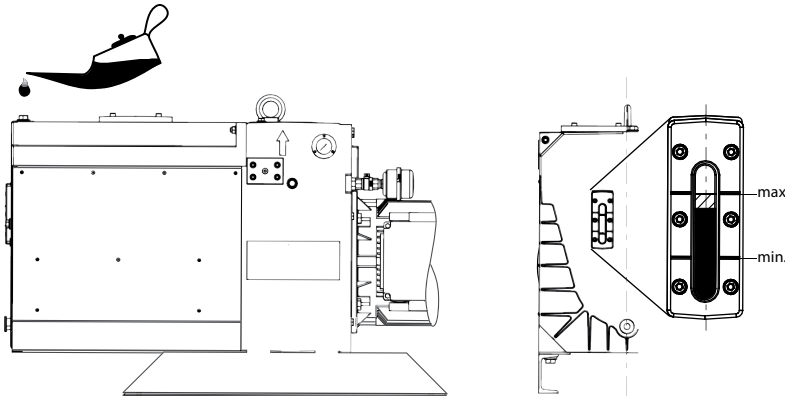

Fig. 8: Filling up the operating fluid



WARNING

Toxic vapours!

Danger of poisoning when igniting and heating synthetic operating fluids (e.g. F4/F5) above 300 °C.

- Observe the application instructions.
- Do not allow operating fluid to make contact with tobacco products; observe safety precautions when handling chemicals.



5.6 Operations monitoring (Option)

For operations monitoring a pressure switch can be installed on the side of the support. In case of a malfunction, e. g. pressure drop or when the pump is at rest, the contact of the pressure switch opens. The signal can be used to control external valves.

| Parameter | Oil pressure switch |
|------------------------|--------------------------------|
| Protection category | IP 55 |
| Contact | Closing contact, normally open |
| Set point | 1000 hPa |
| Switching voltage | 250 V |
| Switching current V AC | 2 A |

1 + 2 closers = pressureless open

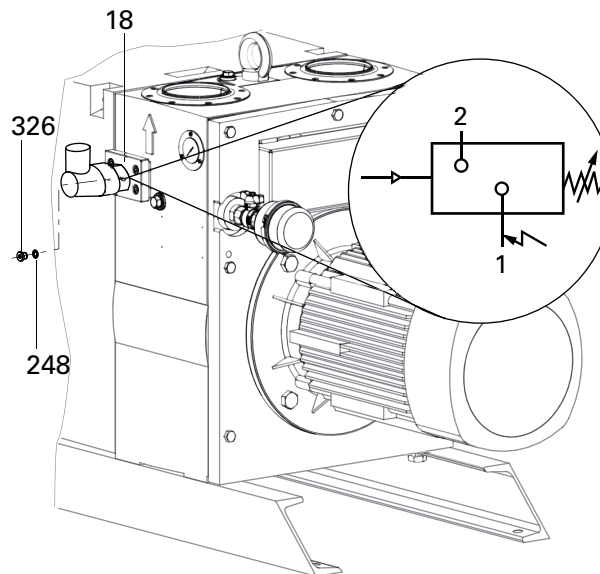

Fig. 9: Installation location and circuit diagram of pressure switch

- Switch off the pump.
- Unscrew screw 326 from the oil passage 18.
- Screw pressure switch with O-ring into oil passage 18.
- Remove protective cover and make electrical connections at the pressure switch.
- Reassemble the protective cover.



6 Operation

6.1 Before switching on the pump

- Check the operating fluid level in the sight glass.
- Compare the voltage and frequency information on the rating plate with the mains voltage and frequency values.
- Check that the exhaust connection allows free flow (max. permissible pressure 1500 hPa absolute).
 - Activate the shut-off valves in such a way that they open before or at the same time as the pump is started.
- Protect the pump sufficiently from taking in contaminants by means of suitable precautions (e.g. dust filters); if necessary, check operating fluid regularly or replace at shorter intervals.

6.2 Switching on the pump

The pump can be switched on in any pressure range between atmospheric and ultimate pressure.

No special precautions are necessary when pumping dry gases. In order to attain the lowest possible ultimate pressures, the gas ballast valve should be closed.



CAUTION

Hot surface!

Danger of burns if hot parts are touched. Depending on the operating and ambient conditions, the surface temperature of the pump may rise above 70 °C.

→ In this case, use suitable finger guards.

- Switch on the pump with the vacuum flange closed and allow to warm up for 30 minutes.
- Check operating fluid level only when the pump is warm and running; therefore
 - close vacuum flange and gas ballast valve,
 - correct filling level during operations: within the markings at the sight glass frame,
 - check operating fluid daily in non-stop operation, otherwise whenever the pump is switched on. Refilling is possible when the pump is in final vacuum operation.



6.3 Pumping condensable vapours

Should the process gases contain condensable gases, the rotary vane pump must be operated with gas ballast (i.e. with an open gas ballast valve).



NOTICE

Bad final vacuum and damage to the pump!

Danger of condensation and corrosion due to exceeding the water vapour compatibility during operation without gas ballast or in case of insufficient supply of flushing gas.

- Only pump vapours when the pump is warm and the gas ballast valve is open.
- When the process has been completed, allow the pump to continue running for about 30 minutes with the vacuum flange closed and the gas ballast open for operating fluid regeneration purposes.

Gas ballast valve, standard version

To avoid condensation in the pump when pumping condensable vapours, air is periodically fed into the working chamber at the beginning of the compression phase via the gas ballast valve 115.

The gas ballast valve is closed when turning to the right to position 0 and open when turning to the left to position 1. Intermediate settings are not possible.

The gas ballast filter is used to keep the air free of particles before entering the suction chamber.

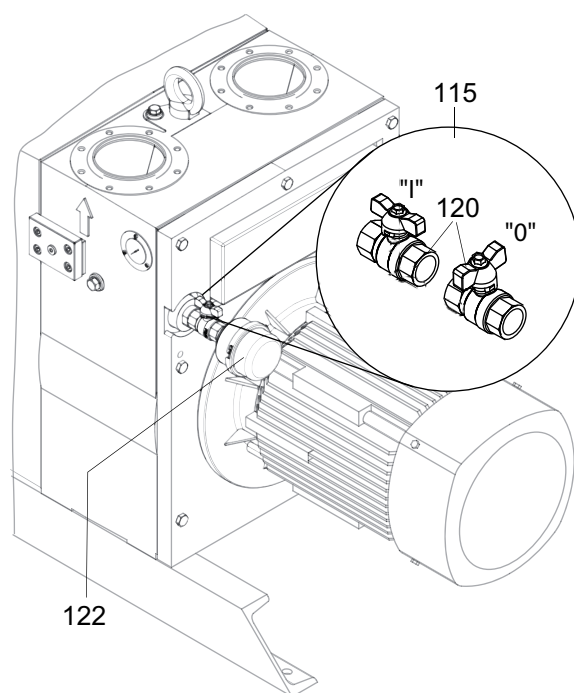

Fig. 10: Standard version of gas ballast valve 115

115 Gas ballast valve (ball valve)

122 Gas ballast filter

Gas ballast valve with flushing gas connection (option)

If the pumping process requires the use of flushing gas, a supply hose can be connected at the gas ballast valve.

- Unscrew gas ballast filter 122 at ball valve 120.
- On the inside thread G 1/2" of ball valve 120, connect the supply line and seal up thread side.
- Set flushing gas pressure on site; maximum pressure 1500 hPa (absolute).
 - Select the type and amount of flushing gas depending on the process; consult Pfeiffer Vacuum if necessary.
- Dose flushing gas with the knob on the ball valve 120 or with a flow meter on site.





NOTICE

Flushing gas pressure higher than allowed endangers the operational reliability of the pump.

The power input of the pump, the temperature and the ejection of operating fluid will increase.

- Observe the maximum permissible flushing gas pressure.
- Set the amount of flushing gas on site.

Gas ballast valve with solenoid valve

The inlet of gas ballast or flushing gas can be controlled by a solenoid valve if a conversion kit is used.

If the process does not require flushing, ambient air can also be admitted via the solenoid valve. For this, remove the hose connection and attach the gas ballast filter 122 to the solenoid valve.

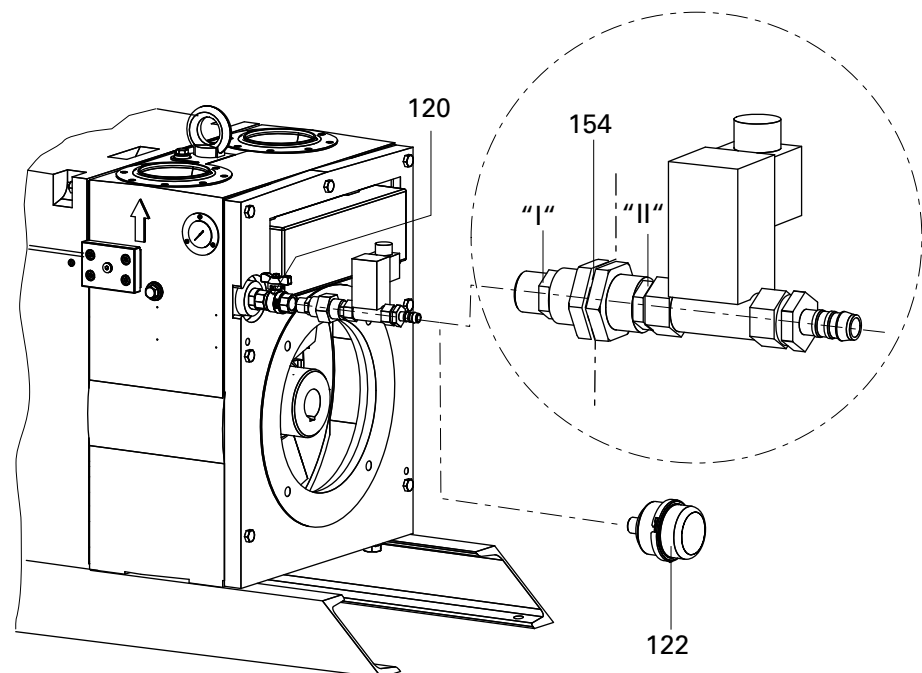

Fig. 11: Assembling the solenoid valve at the gas ballast inlet

| | |
|------------------------------|------------|
| Supply voltage: | 24 V AC/DC |
| Starting power: | 80 W |
| Stopping power: | 6 W |
| Valve closed without current | |

- Remove gas ballast filter 122.
- Unscrew connection 154, take care to ensure the flat gasket is secure.
- Seal the external thread G 1/2" of screw connection part I and attach to ball valve 120.
- Mount the screw connection part II so that the solenoid valve is facing up; take care to ensure the flat gasket is secure.
- Make electrical connections 24 V DC.
- Attach flushing gas to hose connection (NW 12... 14 mm) or after removing the hose nozzle attach to the internal thread G 1/2".
- Set flushing gas pressure; maximum pressure 1500 hPa (absolute).
 - Select the type and amount of flushing gas depending on the process; consult Pfeiffer Vacuum if necessary.
- Dose flushing gas with the knob on the ball valve 120 or with a flow meter on site.



6.4 Topping up the operating fluid

If the operating fluid has reached its minimum filling level, the operating fluid must be topped up. The fluid can be topped up during operation in the final vacuum.

Filling up the operating fluid

- Unscrew operating fluid filler screw 330.
- When the pump is at operation temperature, top up the operating fluid up to the "max." marking.

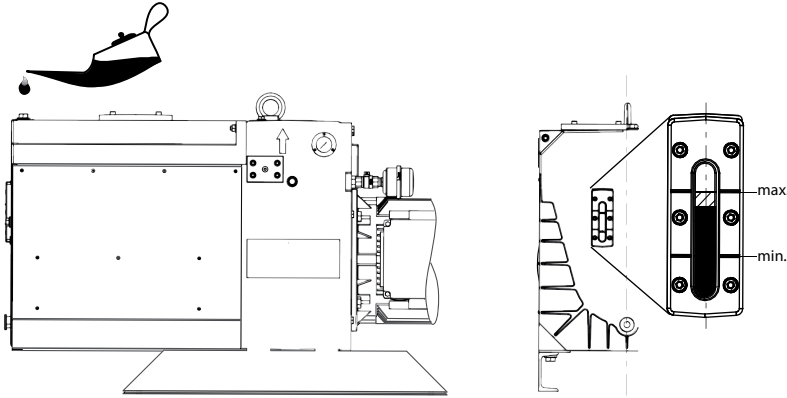

Fig. 12: Filling up the operating fluid

- Screw in operating fluid filler screw 330.



6.5 Switching off the pump

The pump can be switched off in any pressure range.

Rotary vane pumps have an integrated safety valve on the intake side. If the differential pressure between the exhaust side and the intake side is ≥ 250 hPa, then the valve closes automatically and vents the pump when the pump is switched off.

→ Switch the pump off at the mains switch or disconnect from the mains in a secure manner.

Venting the vacuum chamber



NOTICE

Danger of backflow of operating fluid into the intake line!

Contamination of the connected vacuum system!

- Vent the vacuum chamber within 30 s, regardless of the chamber size.
- For a longer venting process, use an additional shut-off valve and shut off the intake line after switching off the pump.

Maintaining the vacuum in the chamber



NOTICE

Danger of backflow of operating fluid into the intake line!

Contamination of the connected vacuum system!

- Because the safety valve of the pump is not suitable for longer-term sealing, install an additional shut-off valve in the intake line.
- Shut off the intake line immediately after switching off the pump.



7 Maintenance

7.1 Precautions



WARNING

Danger of injury from moving parts!

After power failure or motor shutdown due to overheating, the motor may restart automatically.

- Secure the motor so that it cannot be switched on while any work is being performed on the pump.
- If necessary, dismantle the pump from the installation for inspection.



WARNING

Pump parts may be contaminated from pumped media!

Danger of poisoning due to contact with harmful substances.

- Decontaminate the pump before carrying out any maintenance work.
- In the event of contamination, take suitable safety precautions to prevent your health from being harmed by any dangerous substances.

- Turn off the vacuum pump, vent to atmospheric pressure and allow to cool.
- Disconnect the drive motor from the mains and secure it so that it cannot be switched on.
- Only dismantle the pump as far as necessary to carry out maintenance.
- Dispose of used operating fluid in compliance with local regulations.
- When using synthetic operating fluids or working with toxic substances or substances contaminated with corrosive gases, the relevant instructions governing their use must be observed.
- Use only alcohol or similar agents for cleaning pump parts.

Magnetic coupling

The following safety instructions are only valid for the **disassembly** of the drive system for vacuum pumps with **magnetic coupling**!



DANGER

Strong magnetic field in the vicinity of the drive system!

Danger to life for persons with cardiac pacemakers when the drive system is disassembled.

- Persons with cardiac pacemakers must not enter the area ($\leq 2\text{m}$) of the magnetic field.
- Rooms in which open couplings are accessible must be identified: "No trespassing for persons with heart pacemaker"!
- Disassembled magnetic couplings must be kept away from computers, data storage media and other electronic components.



Checklist for inspection, maintenance and overhaul

Certain maintenance and overhaul work should only be performed by Pfeiffer Vacuum Service (PV). Pfeiffer Vacuum will be released from all warranty and liability claims if the required, below listed, intervals are exceeded or maintenance or overhaul procedures are not performed properly. This also applies if replacement parts other than Pfeiffer Vacuum OEM replacement parts are used.

| Activity | K//W/R ¹ | daily | as required; at least annually | as required; at least every 2 years | as required; at least every 4 years |
|--|---------------------|-------|--------------------------------|-------------------------------------|-------------------------------------|
| Check operating fluid level | K | X | | | |
| Visual inspection (leak-tightness/oil leaks) | K | X | | | |
| Check filter insert of external oil mist filter (if existent) | K | X | | | |
| Change operating fluid | I | | X | | |
| Disassemble casing, sight glass and pumping system and clean casing outside (without cleaning agent) | I | | X | | |
| Clean gas ballast valve and silencer | I | | X | | |
| Clean the motor fan cap | I | | X | | |
| Disassemble the pump, clean and exchange seals and wearing parts: ⇒ Radial shaft seal ring ⇒ Coupling half at motor side ⇒ Hydraulic valve ⇒ Exhaust valve tongue ⇒ Valve flap of the gas ballast valve ⇒ Vane springs | W | | | X (PV) | |
| Carry out work in accordance the maintenance and additionally: ⇒ Change vanes ⇒ Change valves, springs and sight glass ⇒ Change silencer nozzle ⇒ Check coupling and exchange if necessary | R | | | | X (PV) |

Depending on the process, the required replacement intervals for the operating fluid and the intervals for inspection, maintenance and overhaul may be shorter than the guide values specified in the table. Consult Pfeiffer Vacuum Service, if necessary.

1. K: Checking, I: Inspection, W: Maintenance, R: Overhaul



7.2 Changing the operating fluid

The service life of the operating fluid is dependent on the application area for the pump. It must be changed if:

- The specified ultimate pressure is no longer reached
- The operating fluid in the sight glass is visibly contaminated, milky, or cloudy
- The operating fluid is thermally aged, identifiable by its color ID value (applies to mineral oils only).



Depending on the applications, Pfeiffer Vacuum recommends determining the exact service life of the operating fluid during the first year of operation.

The replacement interval may vary from the guide value specified by Pfeiffer Vacuum depending on the thermal and chemical loads, and the accumulation of suspended particles and condensation in the operating fluid.



WARNING

Hot operating fluid!

Danger of burns when draining due to contact with skin.

- Wear suitable protective clothing.
- Use a suitable collecting vessel.



WARNING

Operating fluid may contain toxic substances from the pumped media!

Danger of poisoning from the emission of harmful substances from the operating fluid.

- Wear suitable protective clothing and respirators.
- Dispose of operating fluid according to the local regulations



Request safety data sheets for operating fluids and lubricants

from Pfeiffer Vacuum or download at www.pfeiffer-vacuum.com.

- Dispose of operating fluid according to the local regulations.

Draining the operating fluid

- Turn off the vacuum pump, vent to atmospheric pressure and allow to cool.
- Unscrew operating fluid filler screw 330.
- Unscrew operating fluid drain screw 328.
- Drain the operating fluid while still quite hot;
 - to empty the pump fully, tip it forward slightly.

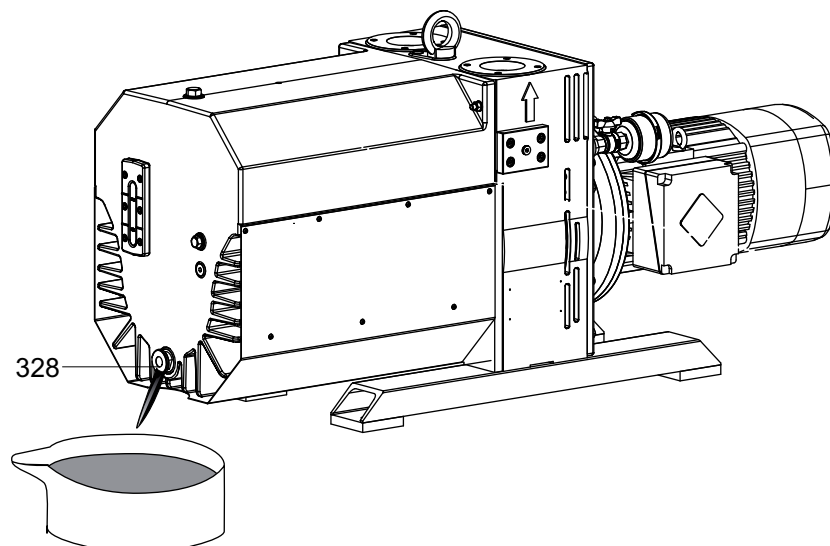

Fig. 13: Draining the operating fluid



- Screw in operating fluid drain screw 328; pay attention to O-ring.
- Screw in operating fluid filler screw 330.
- Allow pump to run for a maximum of 5 seconds with the vacuum flange open.
- Drain off remaining operating fluid.
 - In case of serious contamination, the operating fluid will have to be changed several times (flushing):
- Fill up with operating fluid and check the filling level (*see p. 14, chap. 5.5*).

Determining the level of deterioration

- The level of deterioration of operating fluid P3 can be determined for clean processes with the colour scale (in accordance with DIN 51578); supplementary sheet PK 0219 BN on request or at www.pfeiffer-vacuum.com.
- Suck off operating fluid from the pump through the operating fluid filler opening.
- Fill the specimen in a test tube or some similar vessel and test by holding against the light.
- Where discolouration is red brown (equivalent to 5 on the scale) change operating fluid at the latest.

Flushing and cleaning

If the interior of the pump is heavily contaminated with process residues, we recommend performing several changes of operating fluid to flush away the contamination:

- Operate the pump with the gas ballast open until the pump has warmed up.
- Drain the operating fluid again and check for contamination, flush again if necessary.
- Take off the cap and clean the sight glass and pump system externally (without cleaning agent).
- Replace the filter elements in the accessories.
- Screw the operating fluid drain screw back in.
- Fill up with operating fluid and check the filling level (*see p. 14, chap. 5.5*).
- Screw in operating fluid filler screw 330.



7.3 Changing the kind of operating fluid

When filling up, topping up or changing the operating fluid, always use the type of operating fluid indicated on the pump type plate. If, for example, amended process conditions require the use of a different operating fluid, the fluid can be changed as follows:



NOTICE

Changing the type of operating fluid.

A change of operating fluid type can be only be made between mineral (P3) and synthetic operating fluid (D1). It is not possible to change from these two types to F4/F5 or the other way round!

→ For the two flushing processes and final fill, the pump needs to be filled up three times with fresh operating fluid, and this is the amount of operating fluid required.

- Perform two flushing processes with the new operating fluid.
- Clean any accessories present such as the ONF/OME or ORF/ODK and replace their filter elements; pay attention to whether more operating fluid is required.
- Fill the pump for the final time with the third filling.
- Note down the current type of operating fluid in an appropriate place on the pump (preferably on the type plate).



7.4 Cleaning and re-setting the silencer

If the silencer is not functioning, a knocking noise becomes audible at final vacuum. This does not damage the pump, although can have a negative affect at the installation location.

Dismantling

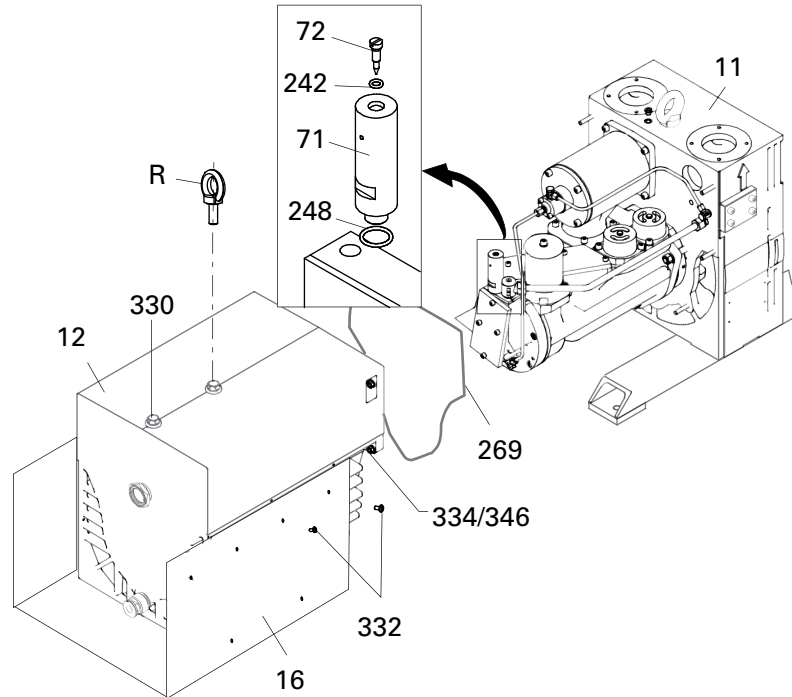

Fig. 14: Dismantle silencer

| | | | | | |
|----|---------------|-----|---------------|-----|------------------------------|
| 11 | Support stand | 72 | Valve spindle | 330 | Operating fluid filler screw |
| 12 | Casing | 242 | O-ring | 332 | Screws |
| 16 | Baffle plate | 248 | O-ring | 334 | Hexagon nut |
| 71 | Valve housing | 269 | O-ring | 346 | Washer |

- Drain off operating fluid.
- Unscrew screws 332 and remove baffle plate 16.
- Lift casing 12 with a chain hoist at eye bolt R or a jack lift. **Caution!** Casing weighs approx. 46 kg.
- Unscrew nuts 334 and remove washers 346.
- Carefully back casing 12 away from support stand 11 in axial direction; pay attention to O-ring 269.
- Dismantle valve housing 71 in axial direction, clean and check radial borehole for free flow.
- Unscrew valve spindle 72.
- Examine O-rings 242/248, valve spindle 72 and valve seat for wear and replace if necessary.
- Reassemble in the reverse sequence. Carefully push O-ring 242 into the nut in valve spindle 72 and oil lightly with operating fluid.

Setting the silencer

The silencer is set using a standard screwdriver when the pump is running at operating temperature and vacuum flange and gas ballast valve are closed:

- Bring pump up to operating temperature.
- Unscrew operating fluid filler screw 330.
- Turn valve spindle 72 approx. 3 rotations using screwdriver (flush), wait a few seconds and then reclose far as it will go (clockwise).
- Slowly open valve spindle 72 (1/2 to 1 rotation) until the oil hammer noise disappears.
- Screw in operating fluid filler screw 330.



7.5 Changing the gas ballast filter

The greater the contamination, the lower the filter air throughput and the greater the risk of condensation and corrosion within the pump.

Standard version

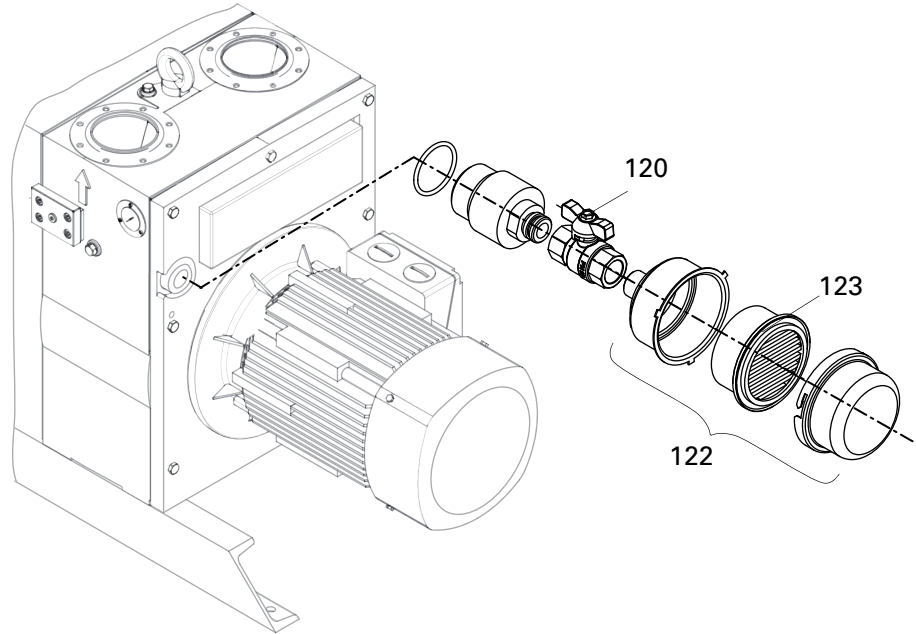

Fig. 15: Gas ballast valve (standard version)

120 Gas ballast valve (ball valve) 123 Filter insert
122 Filter housing

- Turn the cover and open the filter housing 122.
- Clean filter insert 123 or replace as necessary.



7.6 Assembling the motor and coupling

Crown gear coupling

When performing installation work on the coupling, it is important to observe the installation instructions of the coupling manufacturer:

www.ktr.com



NOTICE

Damage to motor bearings

Blows or pressure when mounting the coupling half can damage the motor bearings.

- Clean and lightly oil the shaft journals.
- Push the coupling half onto the shaft. If necessary, warm the coupling half, or use the internal thread in the shaft journal and suitable tools and push the coupling half in place.
- The shaft of the drive motor must be aligned with the pump shaft:
 - Observe the permissible angular and radial displacements.
 - Maintain clearance E so that the crown gear can still move axially.
- Tighten the screws in the coupling half with the prescribed torque and secure the stud bolt with Loctite 243.

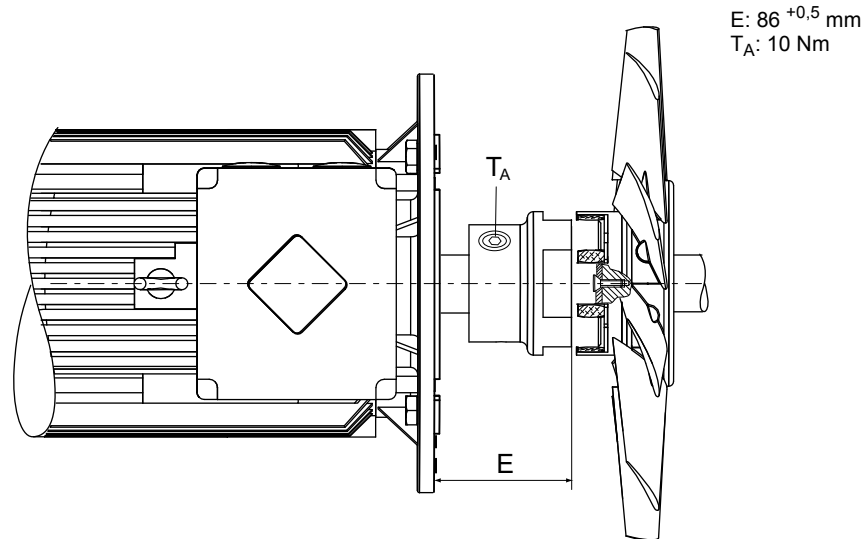

Fig. 16: Assembling the crown gear coupling at pump with standard coupling

Magnetic coupling

The following safety instructions are only valid for the **disassembly** of the drive system for vacuum pumps with **magnetic coupling**!



DANGER

Strong magnetic field in the vicinity of the drive system!

Danger to life for persons with cardiac pacemakers when the drive system is disassembled.

- Persons with cardiac pacemakers must not enter the area ($\leq 2\text{m}$) of the magnetic field.
- Rooms in which open couplings are accessible must be identified: "No trespassing for persons with heart pacemaker"!
- Disassembled magnetic couplings must be kept away from computers, data storage media and other electronic components.



**NOTICE****Danger of bursting when the motor is removed!**

The separating can of the magnetic coupling is made of plastic or ceramics, and can be destroyed when the motor is pulled off.

- Suspend the motor at the eyebolt to the lifting device and pull it off horizontally.
- Use jack screws and guide pins.

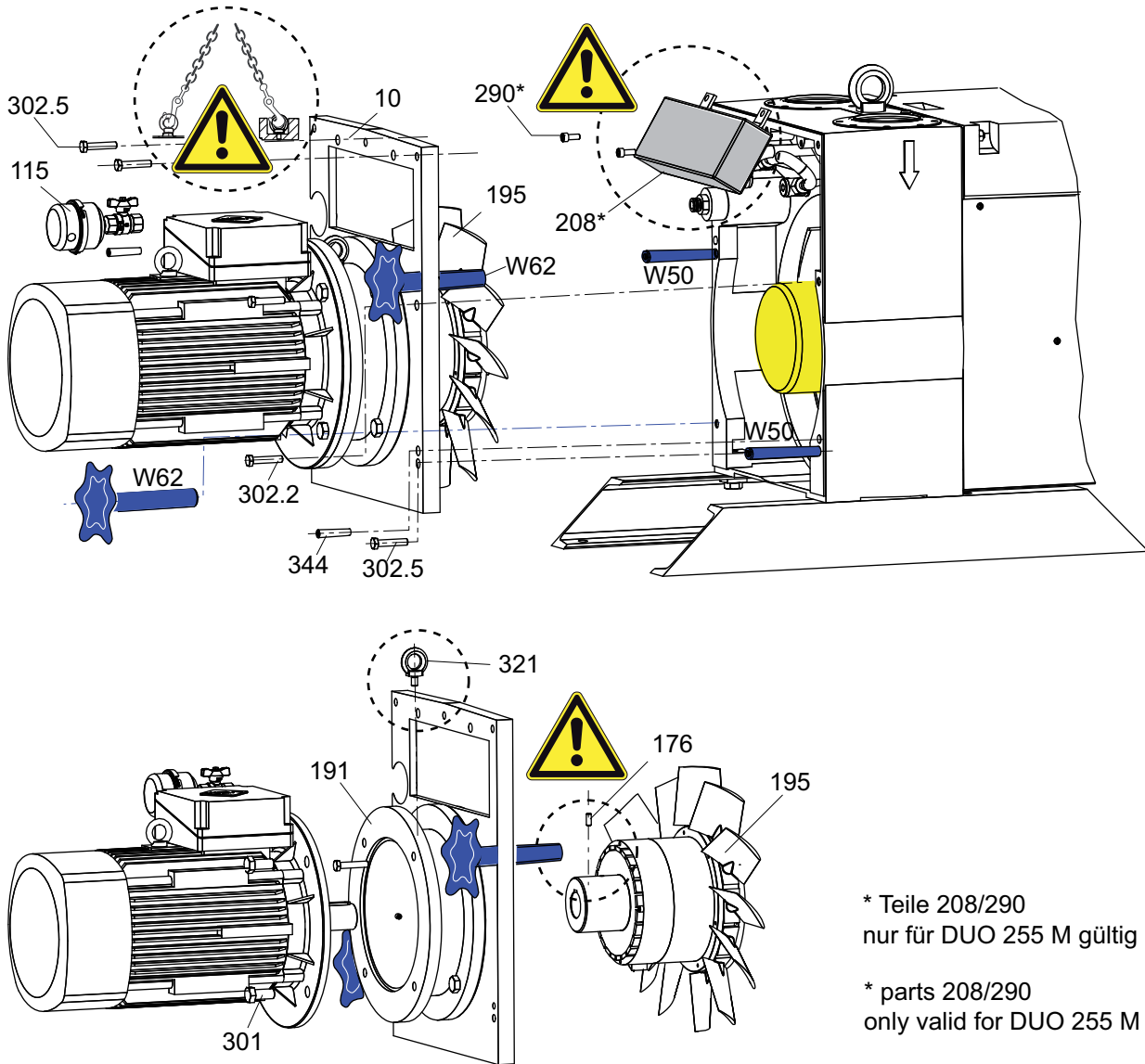

Fig. 17: Dismantling/assembling the drive motor at pumps with magnetic coupling

- Secure motor with chain hoist.
- Remove gas ballast valve 115 from the pump and absorb the operating fluid underneath.
- Pull off taper pins 344 with a pin puller (tool kit).
- Unscrew screws 302.
- Screw in two guide pins F in place of the two screws 302.5.
- Then unscrew the remaining screws 302.5 (5x).
- Press motor, intermediate flange 191 and cover 10 off evenly with two jack screws A and pull off horizontally.
- Detach motor in an axial direction from motor intermediate flange 10.



8 Decommissioning

8.1 Shutting down for longer periods

Before shutting down the pump, observe the following procedure and adequately protect the pump system against corrosion:

- Switch off pump.
- Change operating fluid.
- Start the pump and allow the pump to warm up.
- Switch off the pump.
- Fill up the pump with new operating fluid to the top edge of the sight glass.
- Close vacuum flange and exhaust flange with locking caps.
- Store the pump only indoors, preferably at temperatures between -10 °C and +40 °C.
 - In rooms with moist or aggressive atmospheres, the pump must be airproof shrink-wrapped in a plastic bag together with a bag of desiccant.
 - After storage periods longer than two years, it is recommended to carry out maintenance and change the operating fluid before using the pump.
- Do not store pump in the vicinity of machines, lanes, etc., because strong vibrations can damage the rotor bearings.

8.2 Re-starting



Emission of operating fluid!

Danger of the operating fluid being emitted at the exhaust flange if overfilled.

- Drain the operating fluid to the normal level before restarting the pump.



NOTICE

Re-starting

The serviceability of the operating fluid without operation is a maximum of 2 years. Before restarting after a shut-down of **2 years or longer**, carry out the following work.

- Replace the operating fluid.
- Replace the radial shaft sealing rings and further elastomer parts.
- Replace bearings at pumps with anti-friction bearings.
- Follow the maintenance instructions and inform Pfeiffer Vacuum.

8.3 Disposal

Products or parts thereof (mechanical and electrical components, operating fluids, etc.) may cause environmental burden.

- Safely dispose of the materials according to the locally applicable regulations.



9 Malfunctions

Please note the following instructions should the pump malfunction:



CAUTION

Hot surface!

Danger of burns if hot parts are touched. The surface temperature of the pump may rise above 105 °C in case of malfunction.

→ Carry out work on the pump only after it has cooled to a safe temperature.



NOTICE

Motor overload!

Depending on the malfunction (e.g. blocking during cold start), the motor may not be sufficiently protected by the built-in thermal protection switch from damage through overheating.

→ Implement an additional network safety device.

9.1 Rectifying malfunctions

| Problem | Possible causes | Remedy |
|---|---|---|
| Pump will not start up | No mains voltage or voltage does not correspond to the motor data | Check mains voltage and mains fuse protection; check motor switch |
| | Pump temperature too low | Warm up pump to > 12 °C |
| | Thermal protection switch has responded | Detect and fix cause of overheating; allow pump to cool off if necessary. |
| | Pump system dirty | Clean pump; contact Pfeiffer Vacuum Service if necessary. |
| | Pump system damaged | Clean and overhaul pump; contact Pfeiffer Vacuum Service if necessary. |
| | Motor defective | Replace motor |
| Pump switches off after a while after being started | Thermal protection switch of the motor has responded | Detect and fix cause of overheating; allow motor to cool off if necessary. |
| | Mains fuse protection triggered due to overload (e.g. cold start) | Warm up pump |
| | Exhaust pressure too high | Check opening of exhaust line and exhaust accessories |
| Pump does not attain ultimate pressure | Measurement reading is false | Check gauge, check ultimate pressure without installation connected. |
| | Pump or connected accessories are dirty | Clean pump and check components for contamination. |
| | Operating fluid dirty | Operate pump for a longer period with gas ballast valve open or change operating fluid |
| | Leak in system | Repair leak |
| | Operating fluid filling level too low | Top off operating fluid |
| | Pump damaged | Contact Pfeiffer Vacuum Service. |
| Pumping speed of pump too low | Intake line not well-dimensioned | Keep connections as short as possible and ensure that cross-sections are sufficiently dimensioned |
| | Exhaust pressure too high | Check opening of exhaust line and exhaust accessories |
| Loss of operating fluid | Swivel gasket leaky | Check tightness; replace gasket if necessary |
| | Radial shaft seal ring leaky | Replace seal ring and check bushing |
| | Operational loss of operating fluid, without ONF/OME | Install oil mist filter and oil return unit |
| | Operational loss of operating fluid, with ONF/OME | Clean oil mist filter and oil return unit, change filter respectively |



| Problem | Possible causes | Remedy |
|--------------------------|---------------------------|--|
| Unusual operating noises | Silencer dirty | Clean or replace the silencer. |
| | Damage to the pump system | Clean and overhaul pump; contact Pfeiffer Vacuum Service if necessary. |
| | Motor bearing defective | Replace motor; contact Pfeiffer Vacuum Service if necessary |

| Problem | Possible causes | Remedy |
|--------------------------|--|--|
| Unusual operating noises | Motor runs - pump doesn't (only valid for pumps with magnetic coupling system) | <p>Magnetic coupling system defective or magnetic field "broken away", contact Pfeiffer Vacuum Service if necessary.</p> <p>Attention! Magnetic field: If the magnetic field has "broken away", the orientation of the magnets with respect to each other can only be re-established at standstill. If the pump is left to operate with a "broken away" magnetic field, demagnetisation will take place and the coupling is destroyed.</p> |



| NOTICE | |
|--|--|
| <p>Service work should be carried out by a qualified person only!</p> <p>Pfeiffer Vacuum is not liable for any damage to the pump resulting from work carried out improperly.</p> <p>→ Take advantage of our service training programs; additional information at www.pfeiffer-vacuum.com.</p> <p>→ Please state all the information on the pump rating plate when ordering spare parts.</p> | |



10 Service

Pfeiffer Vacuum offers first-class service!

- Maintenance/repairs on site by Pfeiffer Vacuum field service
- Maintenance/repairs in a nearby service center or service point
- Fast replacement with exchange products in mint condition
- Advice on the most cost-efficient and quickest solution

Detailed information and addresses at: www.pfeiffer-vacuum.com (Service).

Maintenance and repairs in Pfeiffer Vacuum ServiceCenter

The following steps are necessary to ensure a fast, smooth servicing process:

- Download the forms "Service Request" and "Declaration on Contamination".¹⁾
- Fill out the "Service Request" form and send it by fax or e-mail to your Pfeiffer Vacuum service address.
- Include the confirmation on the service request from Pfeiffer Vacuum with your shipment.
- Fill in the contamination declaration and enclose it in the shipment (required!).
- Dismantle all accessories.
- Drain operating fluid/lubricant.
- Drain cooling medium, if used.
- Send the pump or unit in its original packaging if possible.

Sending of contaminated pumps or devices

No units will be accepted if they are contaminated with micro-biological, explosive or radioactive substances. "Hazardous substances" are substances and compounds in accordance with the hazardous goods directive (current version). If pumps are contaminated or the declaration on contamination is missing, Pfeiffer Vacuum performs decontamination at the shipper's expense.

- Neutralise the pump by flushing it with nitrogen or dry air.
- Close all openings airtight.
- Seal the pump or unit in suitable protective film.
- Return the pump/unit only in a suitable and sturdy transport container and send it in while following applicable transport conditions.

Service orders

All service orders are carried out exclusively according to our repair conditions for vacuum units and components.

¹⁾ Forms under www.pfeiffer-vacuum.com

11 Spare parts

11.1 Spare parts packages

The spare parts packages listed here are only applicable for standard models.

Please state all information on the rating plate when ordering spare parts. Other spare parts than those described in this manual must not be used without the agreement of Pfeiffer Vacuum.

| Spare parts package/spare parts | Pump type, revision index | No. | Parts according to the exploded view on the following page |
|-------------------------------------|---------------------------|---------------|---|
| Set of seals | DUO 125 Index "B" | PK E00 024 -T | 47, 48, 99, 144, 147, 242, 244, 245, 247, 248, 250, 251, 255, 256, 258, 260, 262, 263, 264, 265, 266, 268, 269, 270 |
| | DUO 125 M | PK E00 026 -T | 47, 48, 99, 141, 144, 147, 242, 244, 245, 247, 248, 250, 251, 255, 256, 258, 260, 262, 263, 264, 265, 266, 267, 268, 269, 270 |
| Maintenance kit | DUO 125 | PK E01 032 -T | 29, 59, 60, 142, 143, 144, 145, 173, 250, 251, 255, 260, 266, 269 |
| | DUO 125 M | PK E01 034 -T | 31, 59, 60, 250, 251, 255, 260, 266, 269 |
| Overhaul kit | DUO 125 Index "B" | PK E02 037 -T | Set of seals, 24, 29, 30, 31, 38, 47, 52, 56, 57, 59, 60, 65, 72, 81, 88, 98, 99, 123, 143, 145, 148, 173, 270 |
| | DUO 125 M | PK E02 050 -T | Set of seals, 24, 29, 30, 31, 38, 47, 52, 56, 57, 59, 60, 65, 72, 81, 88, 98, 99, 123, 143, 145, 148, 173, 270 |
| Pumping system, tested with P3 | DUO 125 | PK E03 016 -T | 20, 22, 23, 24, 25, 26, 27, 28, 29, 30, 31, 32, 33, 34, 35, 37, 38, 39, 41, 42, 44, 46, 47, 48, 52, 53, 54, 56, 57, 58, 59, 60, 65, 172, 223, 224, 255, 256, 258, 260, 268, 270, 285, 290, 293, 294, 296, 304, 312, 314, 346 |
| | DUO 125 M | PK E03 040 -T | 20, 22, 23, 24, 25, 26, 27, 28, 29, 30, 31, 32, 33, 34, 35, 37, 38, 39, 41, 42, 44, 46, 47, 48, 52, 53, 54, 56, 57, 58, 59, 60, 65, 141, 172, 223, 224, 255, 256, 258, 260, 268, 270, 285, 290, 293, 294, 296, 304, 312, 314, 346 |
| Pumping system, tested with D1 | DUO 125 | PK E03 017 -T | 20, 22, 23, 24, 25, 26, 27, 28, 29, 30, 31, 32, 33, 34, 35, 37, 38, 39, 41, 42, 44, 46, 47, 48, 52, 53, 54, 56, 57, 58, 59, 60, 65, 172, 223, 224, 255, 256, 258, 260, 268, 270, 285, 290, 293, 294, 296, 304, 312, 314, 346 |
| | DUO 125 M | PK E03 041 -T | 20, 22, 23, 24, 25, 26, 27, 28, 29, 30, 31, 32, 33, 34, 35, 37, 38, 39, 41, 42, 44, 46, 47, 48, 52, 53, 54, 56, 57, 58, 59, 60, 65, 141, 172, 223, 224, 255, 256, 258, 260, 268, 270, 285, 290, 293, 294, 296, 304, 312, 314, 346 |
| Vacuum safety valve set | DUO 125 | PK E04 009 -T | 74, 79, 80, 81, 82, 84, 85, 88, 98, 99, 263, 264, 265 |
| Discharge valve set, stage I | DUO 125 | PK E05 013 -T | 48, 52, 53, 54, 258, 294 |
| Discharge valve set, stage II | DUO 125 | PK E05 012 -T | 56, 57, 59, 60 |
| Coupling kit | DUO 125 | PK E06 007 -T | 170, 171, 173, 175, 176 |
| Set of vanes | DUO 125 | PK E08 029 -T | 30, 31, 38 |
| Filter insert for gas ballast valve | DUO 125 | P 0996 094 | 123 |



Exploded view DUO 125, pump complete

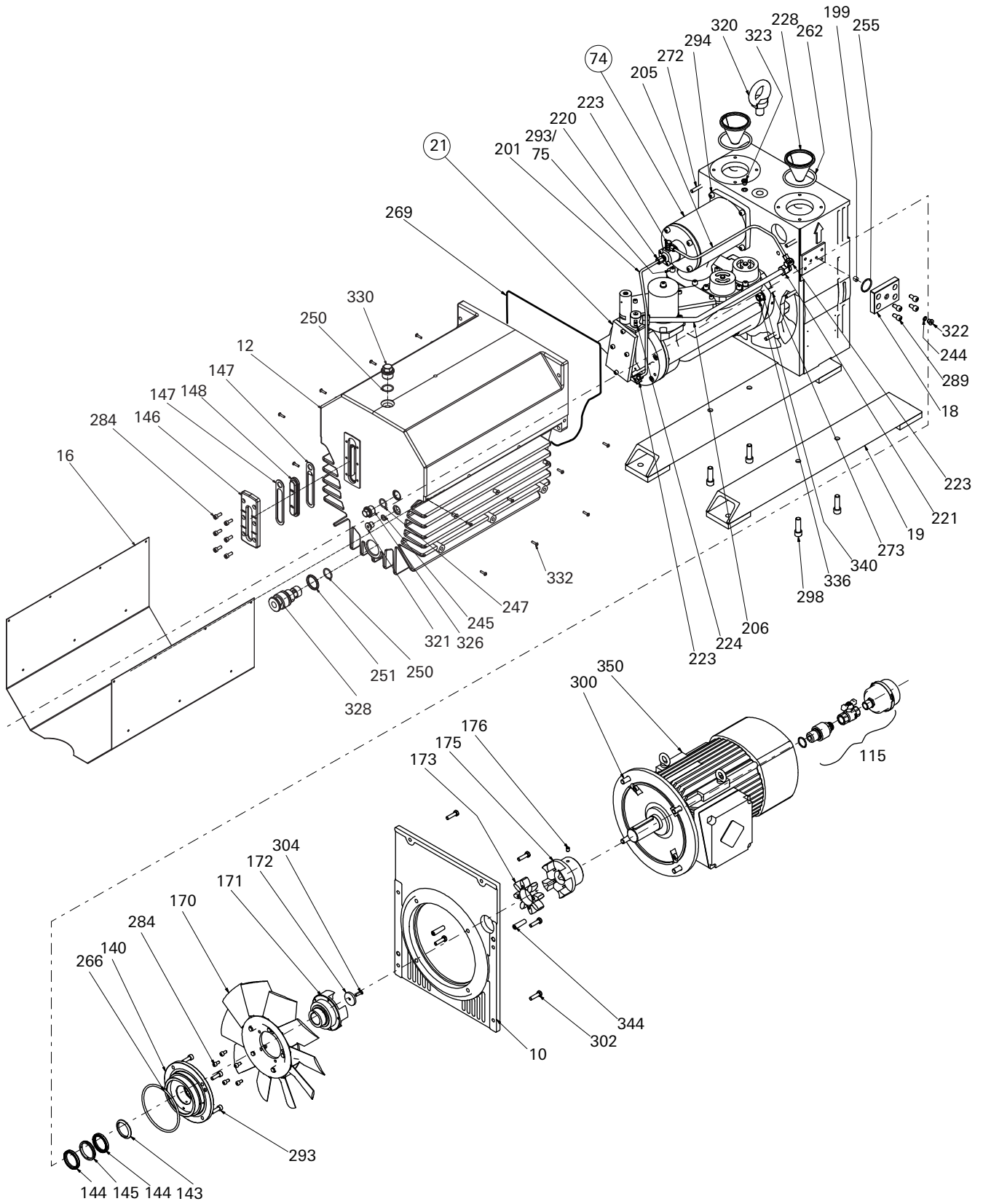

Spare parts

| | | | | | |
|-----|--------------------------------|-----|------------------------------------|-----|------------------------|
| 10 | Cover | 176 | Stud screw for coupling | 273 | Stud screw |
| 11 | Support stand | 199 | Oil nozzle | 284 | Allen head screw |
| 12 | Casing | 201 | Oil pipe, Ø 6 | 289 | Allen head screw |
| 13 | Sealing, casing | 205 | Oil pipe, Ø 6 | 294 | Allen head screw |
| 15 | Sight glass | 206 | Pipe gas ballast, Ø 12 | 298 | Allen head screw, M 12 |
| 16 | Baffle plate | 220 | Straight screwed coupling, G 1/8 " | 300 | Hexagon head screw |
| 17 | Cellular rubber | 221 | Straight screwed coupling, G 3/8" | 302 | Hexagon head screw |
| 18 | Flange, OFM | 223 | Elbow union, G 1/8" | 304 | Countersunk screw |
| 19 | Base | 224 | Elbow union, throttle-free G 3/8 | 320 | Crane eye |
| 21 | Pumping system, complete | 228 | Strainer | 321 | Locking screw |
| 74 | Vacuum safety valve, complete | 244 | O-ring | 322 | Locking screw |
| 75 | Flange ring | 245 | O-ring | 323 | Locking screw, G 1/8 |
| 115 | Gas ballast valve | 247 | O-ring | 326 | Locking screw |
| 140 | Centering flange for rssr. | 250 | O-ring | 328 | Locking screw, G 3/4 |
| 143 | Supporting ring | 251 | O-ring | 330 | Locking screw, G 3/4 |
| 144 | Radial shaft seal ring (rssr.) | 254 | O-ring | 332 | Lens head screw |
| 145 | Spacer | 255 | O-ring | 334 | Hexagon nut |
| 170 | Fan | 262 | O-ring | 336 | Hexagon nut |
| 171 | Coupling half | 264 | O-ring | 340 | Lock washer |
| 172 | Washer | 266 | O-ring | 344 | Tapered pin |
| 173 | Coupling set | 269 | O-ring | 346 | Washer |
| 175 | Coupling half, motor | 272 | Stud screw | 350 | Motor |



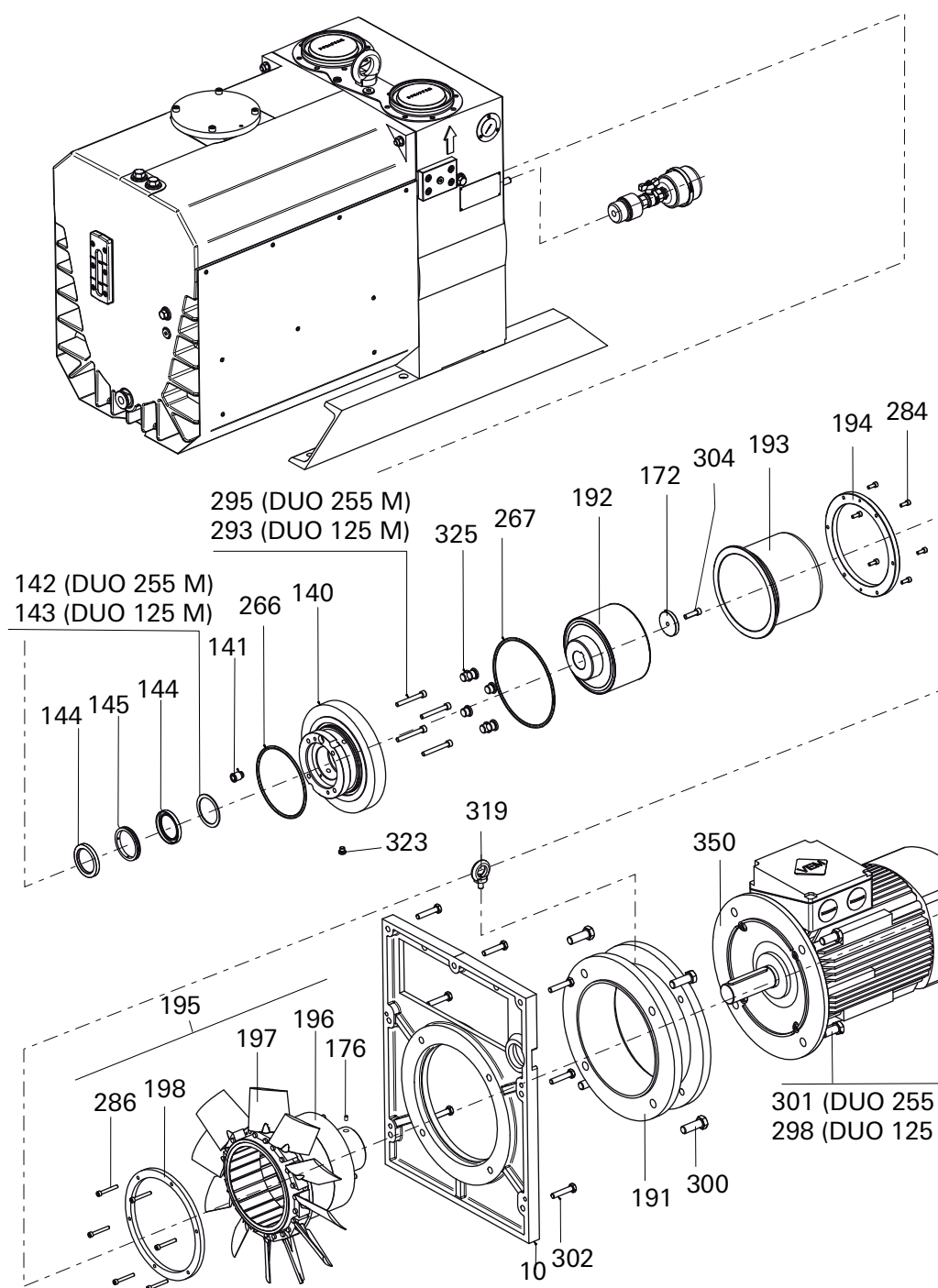
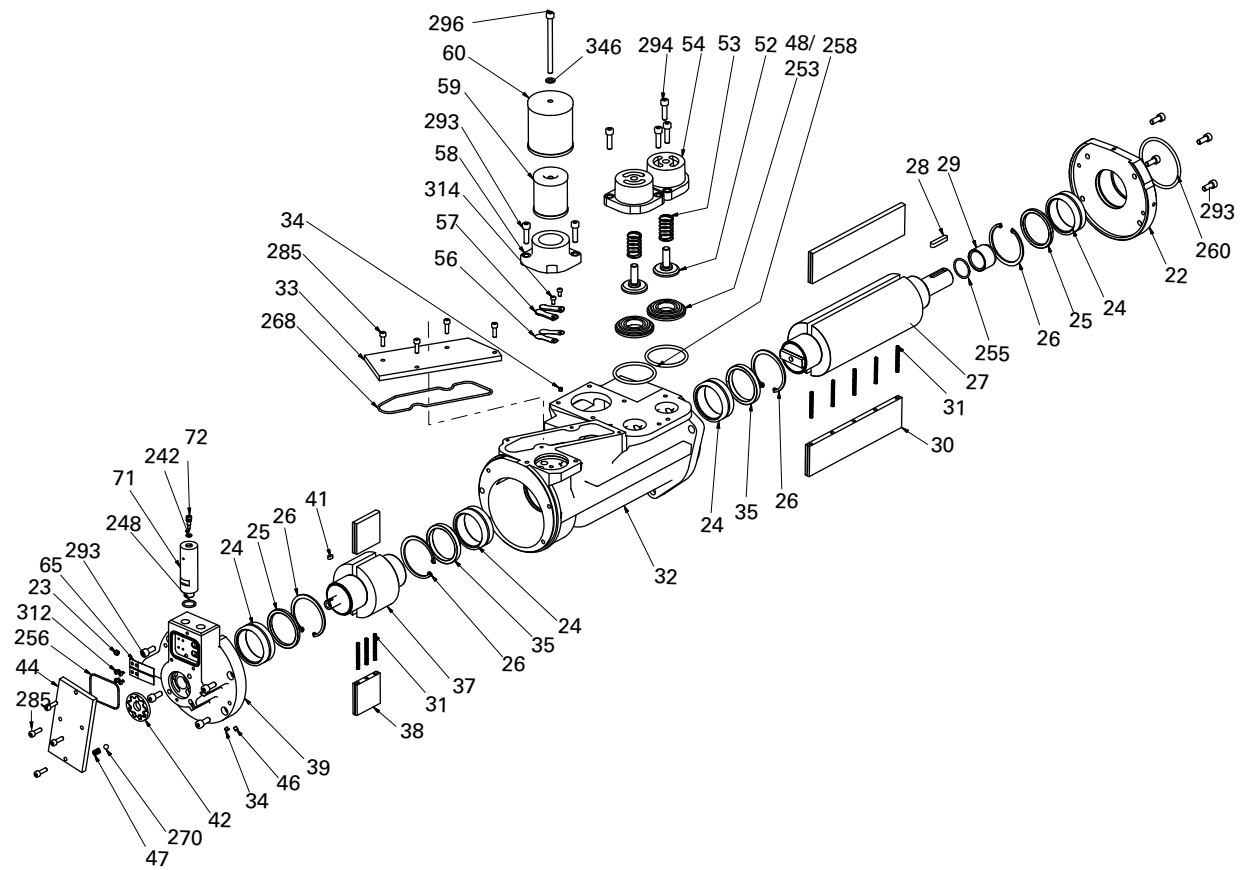

Fig. 18: DUO 125 M with magnetic coupling

| | | | | | |
|-----|--|-----|--------------------------|-----|--------------------|
| 10 | Cover | 192 | Magnetic coupling | 293 | Allen head screw |
| 140 | Centering flange | 193 | Can | 304 | Allen head screw |
| 141 | Sealing nipple (for DUO 125 M in support plate 22) | 194 | Collar flange | 295 | Allen head screw |
| 142 | Washer | 195 | Fan | 298 | Hexagon head screw |
| 143 | Supporting ring | 196 | Magnetic coupling, motor | 300 | Hexagon head screw |
| 144 | Radial shaft seal ring | 197 | Fan blade | 302 | Hexagon head screw |
| 145 | Spacer | 198 | Counter ring, fan | 301 | Hexagon head screw |
| 172 | Washer | 266 | O-ring | 319 | Eye bolt |
| 176 | Stud screw | 267 | O-ring | 323 | Locking screw |
| 191 | Motor intermediate flange | 284 | Allen head screw | 325 | Locking screw |
| | | 286 | Allen head screw | 350 | Motor |



Exploded view DUO 125, pumping system



- | | | | | | |
|----|--|----|------------------------------------|-----|------------------|
| 22 | Support plate | 39 | Bearing cover | 71 | Valve housing |
| 23 | Set screw | 41 | Key | 72 | Valve stem |
| 24 | Needle bearing | 42 | Oil pump | 242 | O-ring |
| 25 | Cover ring for needle bearing | 44 | Cover, oil pump | 248 | O-ring |
| 26 | Circlip for needle bearing | 46 | Set screw | 255 | O-ring |
| 27 | Rotor I | 47 | Pressure spring for oil pump | 256 | O-ring |
| 28 | Key | 48 | Valve seat, complete | 258 | O-ring |
| 29 | Protective sleeve for radial shaft seal ring | 52 | Valve stamp, stage I | 260 | O-ring |
| 30 | Vanes, stage I | 53 | Pressure spring for valve, stage I | 268 | O-ring |
| 31 | Pressure spring | 54 | Valve housing, stage I | 270 | Ball |
| 32 | Cylinder | 56 | Valve plate, stage II | 285 | Allen head screw |
| 33 | Cover cylinder passage | 57 | Valve trap, stage II | 293 | Allen head screw |
| 34 | Nozzle | 58 | Valve top, stage II | 294 | Allen head screw |
| 35 | Cover ring | 59 | Oil filter | 296 | Allen head screw |
| 37 | Rotor II | 60 | Sieve box of valve, stage II | 312 | Allen head screw |
| 38 | Vanes, stage II | 65 | Plate spring of non-return valve | 314 | Allen head screw |
| | | 70 | Silencer, complete | 346 | Washer |



Exploded view DUO 125, vacuum safety valve

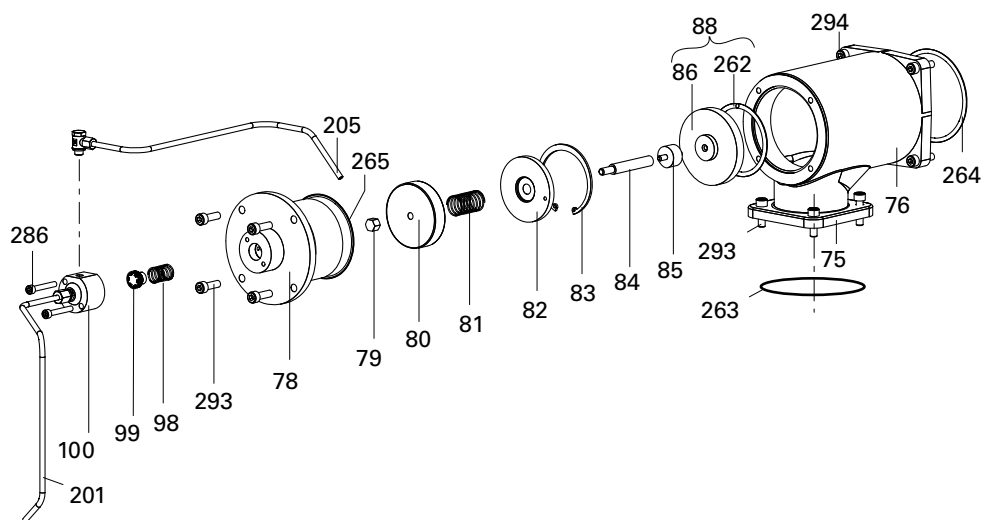

| | | | | | |
|----|---------------------------------|-----|------------------|-----|------------------|
| 75 | Flange ring | 83 | Circlip | 262 | O-ring |
| 76 | Valve housing | 84 | Valve stem | 263 | O-ring |
| 78 | Valve cover for hydraulic valve | 85 | Buffer | 264 | O-ring |
| 79 | Hexagon cap nut | 86 | Valve plate | 265 | O-ring |
| 80 | Piston | 98 | Pressure spring | 286 | Allen head screw |
| 81 | Pressure spring | 99 | Hydraulic piston | 293 | Allen head screw |
| 82 | Guiding piece | 100 | Hydraulic flange | 294 | Allen head screw |

12 Accessories

Further detailed accessories are contained in the Pfeiffer Vacuum printed or Online Catalogue.

| Designation | Duo 125 | Duo 125 M |
|---|---------------|---------------|
| SAS 63 dust separator, DN 63 ISO-K, polyester filter | PK Z60 511 | PK Z60 511 |
| KAS 63, condensate separator for pumping speeds up to 360 m ³ /h | PK Z10 010 | PK Z10 010 |
| OME 63, oil mist filter for pumping speeds of up to 135 m ³ /h | PK Z40 010 | PK Z40 010 |
| OFM 125, mechanical oil filter | PK Z90 340 | PK Z90 340 |
| ZFO 063, zeolite trap | PK Z70 010 | PK Z70 010 |
| FAK 063, activated carbon filter | PK Z30 010 | PK Z30 010 |
| KLF 063, cold trap | PK Z80 010 | PK Z80 010 |
| Oil pressure switch for Duo 125/255 | PK 223 806 -T | PK 223 806 -T |
| PTC-resistor tripping device | P 4768 051 FQ | P 4768 051 FQ |
| Operations monitoring unit 3 for Duo 35/65, Duo 125/255 | PK 223 739 -U | PK 223 739 -U |
| Operating fluid level monitoring | PK 006 001 -T | PK 006 001 -T |
| Temperature sensor for operating fluid | PK 006 040 -T | PK 006 040 -T |
| Gas ballast valve - conversion kit with magnet valve, 24 V DC | PK 215 795 -T | PK 215 795 -T |
| Oil return unit, ORF 005, standard version | PK Z90 065 | PK Z90 065 |



13 Technical data

13.1 General

- Recommendations of PNEUROP committee PN5
- ISO 21360; 2007: "Vacuum technology - Standard methods for measuring vacuum-pump performance - General description"

Conversion table: pressure units

| | mbar | bar | Pa | hPa | kPa | Torr mm Hg |
|---------------|------|----------------------|----------------|------|-------------------|---------------------|
| mbar | 1 | $1 \cdot 10^{-3}$ | 100 | 1 | 0.1 | 0.75 |
| bar | 1000 | 1 | $1 \cdot 10^5$ | 1000 | 100 | 750 |
| Pa | 0.01 | $1 \cdot 10^{-5}$ | 1 | 0.01 | $1 \cdot 10^{-3}$ | $7.5 \cdot 10^{-3}$ |
| hPa | 1 | $1 \cdot 10^{-3}$ | 100 | 1 | 0.1 | 0.75 |
| kPa | 10 | 0.01 | 1000 | 10 | 1 | 7.5 |
| Torr mm Hg | 1.33 | $1.33 \cdot 10^{-3}$ | 133.32 | 1.33 | 0.133 | 1 |

$1 \text{ Pa} = 1 \text{ N/m}^2$

Conversion table: gas throughput units

| | mbar·l/s | Pa·m ³ /s | sccm | Torr·l/s | atm·cm ³ /s |
|------------------------|----------------------|----------------------|------|----------------------|------------------------|
| mbar·l/s | 1 | 0.1 | 59.2 | 0.75 | 0.987 |
| Pa·m ³ /s | 10 | 1 | 592 | 7.5 | 9.87 |
| sccm | $1.69 \cdot 10^{-2}$ | $1.69 \cdot 10^{-3}$ | 1 | $1.27 \cdot 10^{-2}$ | $1.67 \cdot 10^{-2}$ |
| Torr·l/s | 1.33 | 0.133 | 78.9 | 1 | 1.32 |
| atm·cm ³ /s | 1.01 | 0.101 | 59.8 | 0.76 | 1 |



13.2 Technical data

| Parameter | Duo 125 |
|--|---|
| Flange (in) | DN 63 ISO-F |
| Flange (out) | DN 63 ISO-F |
| Pumping speed at 50 Hz | 115 m ³ /h |
| Pumping speed at 60 Hz | 135 m ³ /h |
| Ultimate pressure with gas ballast | 4 · 10 ⁻³ hPa |
| Ultimate pressure without gas ballast | 2 · 10 ⁻³ hPa |
| Exhaust pressure, min. | 250 hPa |
| Exhaust pressure, max. | 1500 hPa |
| Rotation speed at 50 Hz | 1000 min ⁻¹ |
| Rotation speed at 60 Hz | 1200 min ⁻¹ |
| Leak rate safety valve | ≤ 1 · 10 ⁻⁵ Pa m ³ /s |
| Emission sound pressure level without gas ballast at 50 Hz | ≤ 75 dB (A) |
| Ambient temperature | 12-40 °C |
| Protection category | IP 55 |
| Rated power 50 Hz | 4.0 kW |
| Rated power 60 Hz | 4.5 kW |
| Switch | No |
| Mains cable | No |
| Shipping and storage temperature | -25-+55 °C |
| Operating fluid filling | 14 l |
| Weight | 225 kg |
| Cooling method, standard | Air |
| Typical ultimate pressure according to PNEUROP | |

| Parameter | Duo 125 M |
|--|---|
| Flange (in) | DN 63 ISO-F |
| Flange (out) | DN 63 ISO-F |
| Pumping speed at 50 Hz | 115 m ³ /h |
| Pumping speed at 60 Hz | 135 m ³ /h |
| Ultimate pressure with gas ballast | 4 · 10 ⁻³ hPa |
| Ultimate pressure without gas ballast | 2 · 10 ⁻³ hPa |
| Exhaust pressure, min. | 250 hPa |
| Exhaust pressure, max. | 1500 hPa |
| Rotation speed at 50 Hz | 1000 min ⁻¹ |
| Rotation speed at 60 Hz | 1200 min ⁻¹ |
| Leak rate safety valve | ≤ 1 · 10 ⁻⁵ Pa m ³ /s |
| Leak rate magnetic coupling | ≤ 1 · 10 ⁻⁷ Pa m ³ /s |
| Emission sound pressure level without gas ballast at 50 Hz | ≤ 75 dB (A) |
| Ambient temperature | 12-40 °C |
| Protection category | IP 55 |
| Rated power 50 Hz | 4.0 kW |
| Rated power 60 Hz | 4.5 kW |
| Switch | No |
| Mains cable | No |
| Shipping and storage temperature | -25-+55 °C |
| Operating fluid filling | 14 l |
| Weight | 245 kg |
| Cooling method, standard | Air |
| Typical ultimate pressure according to PNEUROP | |



13.3 Dimensions

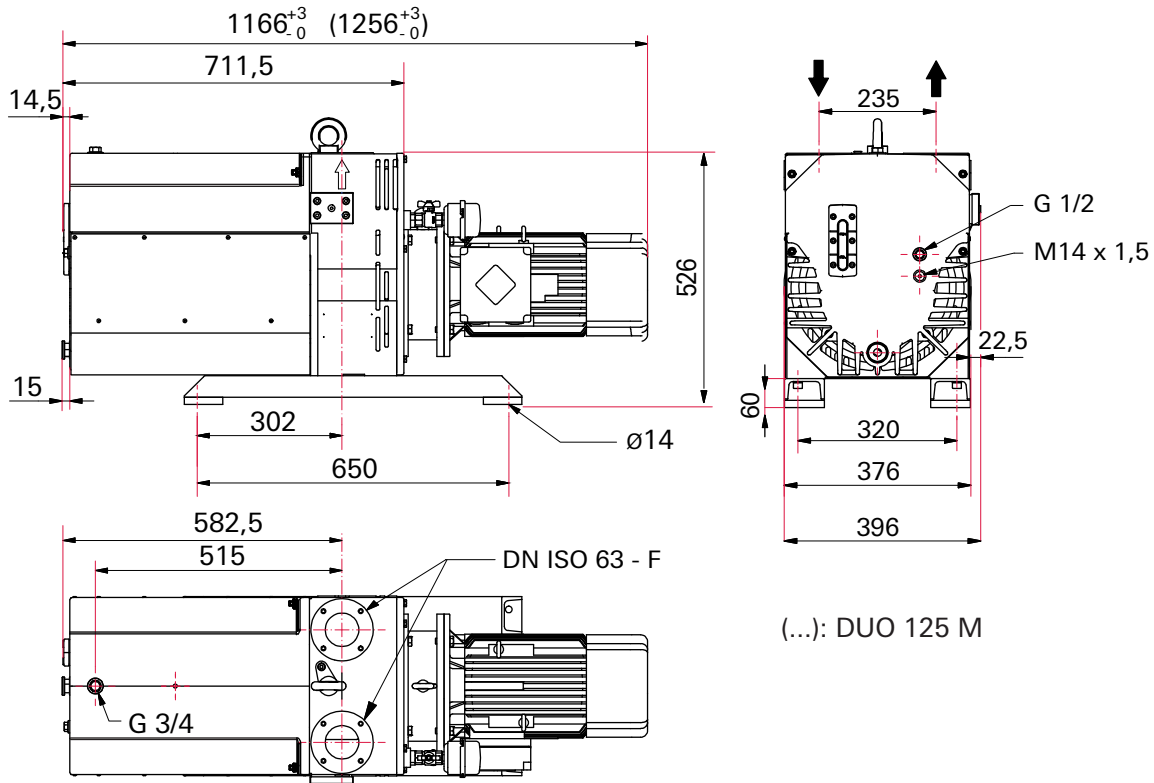

Fig. 19: DUO 125, DUO 125 M





Declaration of conformity

We hereby declare that the product cited below satisfies all relevant provisions according to the following **EC directives**:

- **Machinery 2006/42/EC (Annex II, no. 1 A)**
- **Electromagnetic Compatibility 2014/30/EU**
- **Restriction of the use of certain Hazardous Substances 2011/65/EU**

The agent responsible for compiling the technical documentation is Mr. Sebastian Oberbeck, Pfeiffer Vacuum GmbH, Berliner Straße 43, 35614 Asslar.

DuoLine™
DUO 125

Harmonised standards and national standards and specifications which have been applied:

| | | |
|-------------------------|-------------------------|------------------------------------|
| DIN EN ISO 12100 : 2010 | DIN EN 61010-1 : 2010 | DIN EN 61000-6-3 : 2007 + A1: 2011 |
| DIN EN 1012-2 : 2011-12 | DIN EN 61000-6-1 : 2007 | DIN EN 61000-6-4 : 2007 + A1: 2011 |
| DIN EN ISO 13857 : 2008 | DIN EN 61000-6-2 : 2006 | DIN EN ISO 2151 : 2: 2008 |
| ISO 21360-1, 2 : 2012 | | |

Signature:

Pfeiffer Vacuum GmbH
Berliner Straße 43
35614 Asslar
Germany

(Dr. Ulrich von Hülsen)
Managing Director

2016-04-20



VACUUM SOLUTIONS FROM A SINGLE SOURCE

Pfeiffer Vacuum stands for innovative and custom vacuum solutions worldwide, technological perfection, competent advice and reliable service.

COMPLETE RANGE OF PRODUCTS

From a single component to complex systems:

We are the only supplier of vacuum technology that provides a complete product portfolio.

COMPETENCE IN THEORY AND PRACTICE

Benefit from our know-how and our portfolio of training opportunities!

We support you with your plant layout and provide first-class on-site service worldwide.

Are you looking for a
perfect vacuum solution?
Please contact us:

Pfeiffer Vacuum GmbH
Headquarters • Germany
T +49 6441 802-0
info@pfeiffer-vacuum.de

www.pfeiffer-vacuum.com

PFEIFFER  **VACUUM**

