



OPERATING INSTRUCTIONS

EN

Translation of the Original

PKR 251

Pirani/Cold cathode gauge

PFEIFFER  **VACUUM**



Dear customer,

Thank you for choosing a Pfeiffer Vacuum product. Your new gauge is designed to support you in your individual application with maximum performance and without malfunctions. The name Pfeiffer Vacuum stands for high-quality vacuum technology, a comprehensive and complete range of top-quality products and first-class service. From this extensive, practical experience we have gained a large volume of information that can contribute to efficient deployment and to your personal safety.

In the knowledge that our product must avoid consuming work output, we trust that our product can offer you a solution that supports you in the effective and trouble-free implementation of your individual application.

Please read these operating instructions before putting your product into operation for the first time. If you have any questions or suggestions, please feel free to contact info@pfeiffer-vacuum.de.

Further operating instructions from Pfeiffer Vacuum can be found in the [Download Center](#) on our website.

Disclaimer of liability

These operating instructions describe all models and variants of your product. Note that your product may not be equipped with all features described in this document. Pfeiffer Vacuum constantly adapts its products to the latest state of the art without prior notice. Please take into account that online operating instructions can deviate from the printed operating instructions supplied with your product.

Furthermore, Pfeiffer Vacuum assumes no responsibility or liability for damage resulting from the use of the product that contradicts its proper use or is explicitly defined as foreseeable misuse.

Copyright

This document is the intellectual property of Pfeiffer Vacuum and all contents of this document are protected by copyright. They may not be copied, altered, reproduced or published without the prior written permission of Pfeiffer Vacuum.

We reserve the right to make changes to the technical data and information in this document.



Table of contents

1	About this manual	7
1.1	Validity	7
	1.1.1 Applicable documents	7
	1.1.2 Variants	7
1.2	Target group	7
1.3	Conventions	8
	1.3.1 Instructions in the text	8
	1.3.2 Pictographs	8
	1.3.3 Stickers on the product	8
	1.3.4 Abbreviations	9
1.4	Trademarks	9
2	Safety	10
2.1	General safety instructions	10
2.2	Safety instructions	10
2.3	Safety precautions	13
2.4	Proper use	14
2.5	Foreseeable improper use	14
2.6	Responsibilities and warranty	14
2.7	Owner requirements	14
2.8	Personnel qualification	15
	2.8.1 Ensuring personnel qualification	15
	2.8.2 Personnel qualification for maintenance and repair	15
	2.8.3 Advanced training with Pfeiffer Vacuum	15
2.9	Operator requirements	16
3	Transportation and storage	17
4	Product description	18
4.1	Identifying the product	18
4.2	Scope of delivery	18
4.3	Function	18
5	Installation	19
5.1	Establishing the vacuum connection	19
5.2	Removing/installing the magnetic unit	20
5.3	Establishing the electrical connection	21
6	Operation	24
6.1	Status display	24
6.2	Relation: measuring signal and pressure	25
6.3	Gas type dependence	26
6.4	Ignition delay	28
6.5	Contamination	28
7	Disassembly	30
8	Maintenance	32
8.1	Calibrating the gauge	32
8.2	Disassembling the gauge	34
8.3	Cleaning of components	35
8.4	Assembling the gauge	37
9	Malfunctions	39
10	Shipping	40
11	Disposal	41

12	Service solutions from Pfeiffer Vacuum	42
13	Ordering information	44
	13.1 Ordering parts	44
	13.2 Spare parts	44
	13.3 Accessories	45
14	Technical data and dimensions	46
15	Appendix	49
	15.1 Units of pressure	49
	15.2 Gas throughputs	49
	ETL Listed	50
	Declaration of conformity	51



List of tables

Tbl. 1:	Applicable documents	7
Tbl. 2:	Variants	7
Tbl. 3:	Abbreviations used	9
Tbl. 4:	Operating modes	24
Tbl. 5:	Constants	25
Tbl. 6:	Conversion table	26
Tbl. 7:	Calibration factors for the pressure range < 10 hPa	28
Tbl. 8:	Malfunctions	39
Tbl. 9:	Measuring and pressure values	46
Tbl. 10:	Electrical data	47
Tbl. 11:	Internal volume and weight	47
Tbl. 12:	Ambient conditions	47
Tbl. 13:	Temperatures	47
Tbl. 14:	Material against vacuum	47
Tbl. 15:	Units of pressure and their conversion	49
Tbl. 16:	Gas throughputs and their conversion	49



List of figures

Fig. 1:	Measuring configuration	18
Fig. 2:	Establishing the vacuum connection	20
Fig. 3:	Removing/installing the magnetic unit (recommended for CF-F)	21
Fig. 4:	Connection diagram	22
Fig. 5:	Measurement cable and Hirschmann cable socket	22
Fig. 6:	Light emitting diode (LED)	24
Fig. 7:	Relation: measuring signal and pressure	25
Fig. 8:	Pressure range > 10 hPa, solely Pirani operation	26
Fig. 9:	Pressure range from 10 up to 0.1 hPa	27
Fig. 10:	Disassembling the gauge	30
Fig. 11:	Calibrating the gauge (HV)	33
Fig. 12:	Calibrating the gauge (ATM)	33
Fig. 13:	Individual parts	34
Fig. 14:	Mounting tool for the ignition aid	37
Fig. 15:	Spare parts	44
Fig. 16:	Filter disk	45
Fig. 17:	Dimensions	48



1 About this manual



IMPORTANT

Read carefully before use.
Keep the manual for future consultation.

1.1 Validity

This document describes the function of the products listed in the following and provides the most important information for safe use. The description is written in accordance with the valid directives. The information in this document refers to the current development status of the products. The document retains its validity assuming that the customer does not make any changes to the product.

1.1.1 Applicable documents

Designation	Document
Brief instructions for "Pirani/Cold cathode gauge" PKR 251	BG 5119
Operating instructions "Total pressure measuring and control unit" TPG 361 TPG 362	BG 5500
Operating instructions "Total pressure measuring and control unit" TPG 366	BG 5501
Declaration of conformity	(Part of this document)

Tbl. 1: Applicable documents

The brief instructions for the gauge are included in the scope of delivery.

1.1.2 Variants

This document applies to products with the following part numbers:

Part number	Designation
PT R26 000	PKR 251 (DN 25 ISO-KF)
PT R26 001	PKR 251 (DN 40 ISO-KF)
PT R26 002	PKR 251 (DN 40 CF-F)

Tbl. 2: Variants

Information that relates to only one of the devices is indicated as such. Unless otherwise indicated, the illustrations correspond to the device with DN 25 ISO-KF vacuum connection, however, also apply for the other vacuum connections accordingly.

The part number is found on the rating plate of the product.

Pfeiffer Vacuum reserves the right to make technical changes without prior notification.

The figures in this document are not to scale (dimensions in mm).

1.2 Target group

These operating instructions are aimed at all persons performing the following activities on the product:

- Transportation
- Setup (Installation)
- Usage and operation
- Decommissioning
- Maintenance and cleaning
- Storage or disposal

The work described in this document is only permitted to be performed by persons with the appropriate technical qualifications (expert personnel) or who have received the relevant training from Pfeiffer Vacuum.

1.3 Conventions

1.3.1 Instructions in the text

Usage instructions in the document follow a general structure that is complete in itself. The required action is indicated by an individual step or multi-part action steps.

Individual action step

A horizontal, solid triangle indicates the only step in an action.

- ▶ This is an individual action step.

Sequence of multi-part action steps

The numerical list indicates an action with multiple necessary steps.

1. Step 1
2. Step 2
3. ...

1.3.2 Pictographs

The pictographs used in the document indicate useful information.



Note



Tip



Wear laboratory gloves



Perform a visual inspection

1.3.3 Stickers on the product

This section describes all the stickers on the product along with their meaning.

	<p>Rating plate</p> <p>The rating plate is located on the top of the device.</p>
	<p>Warning against magnetic fields</p> <p>The sticker displays a warning that the magnetic field of the gauge can interfere with the functioning of pacemakers, and specifies the minimum distance to the gauge which must be maintained by persons with pacemaker implants.</p>



1.3.4 Abbreviations

Abbreviation	Explanation
ATM	Atmosphere
HV	High vacuum
cpl.	Complete unit
MSL	Mean sea level
s	Seconds
WAF	Width across flats

Tbl. 3: Abbreviations used

1.4 Trademarks

- FullRange® is a trademark of Pfeiffer Vacuum GmbH.

2 Safety

2.1 General safety instructions

This document includes the following 4 risk levels and 1 information level.

⚠ DANGER
<p>Imminent danger</p> <p>Indicates a hazardous situation which, if not avoided, will result in death or serious injury.</p> <ul style="list-style-type: none"> ▶ Instructions on avoiding the hazardous situation

⚠ WARNING
<p>Possibly imminent danger</p> <p>Indicates a hazardous situation which, if not avoided, could result in death or serious injury.</p> <ul style="list-style-type: none"> ▶ Instructions on avoiding the hazardous situation

⚠ CAUTION
<p>Possibly imminent danger</p> <p>Indicates a hazardous situation which, if not avoided, could result in minor or moderate injury.</p> <ul style="list-style-type: none"> ▶ Instructions on avoiding the hazardous situation

NOTICE
<p>Danger of property damage</p> <p>Notice is used to address practices not related to physical injury.</p> <ul style="list-style-type: none"> ▶ Instructions on avoiding property damage

i	Notes, tips or examples indicate important information on the product or on this document.
----------	--

2.2 Safety instructions

i	<p>Safety instructions according to product's life stages</p> <p>All safety instructions in this document are based on the results of a risk assessment. Pfeiffer Vacuum has taken into account all the relevant life stages of the product.</p>
----------	---

Risks during transportation

NOTICE
<p>Damage caused by incorrect transportation</p> <p>Transportation in unsuitable packaging, or failure to install all transport locks, can damage the product.</p> <ul style="list-style-type: none"> ▶ Comply with the instructions for safe transportation.

Risks during storage

NOTICE
<p>Damage caused by improper storage</p> <p>Improper storage will lead to damage to the product.</p> <p>Static charging, moisture, etc. lead to defects on the electronic components.</p> <ul style="list-style-type: none"> ▶ Comply with the instructions for safe storage.



Risks during installation

⚠ DANGER**Danger to life due to dangerous contact voltage**

Voltages above 30 V (AC) or 60 V (DC) are considered dangerous in accordance with EN 61010. If you come into contact with dangerous contact voltage, this can result in injury through electric shocks or even death.

- ▶ Only connect the product to devices which meet the following criteria:
 - Requirements of the earthed protective extra-low voltage (PELV)
 - Limited power source (LPS) Class 2
- ▶ Secure the line to the product.
 - Pfeiffer Vacuum measuring and control equipment complies with this requirement.

⚠ DANGER**Risk to life due to electric shock**

An improperly earthed product is potentially fatal in the event of a fault.

- ▶ Connect the product galvanically with the earthed vacuum chamber.
- ▶ Ensure that the connection complies with the requirements of a protective bonding according to EN 61010. (CF and VCR connections comply with this requirement.)
- ▶ Use electrically conductive centering rings and circlips for KF connections.

⚠ WARNING**Danger from magnetic fields**

The product has a magnetic field that disturbs or impairs the function of electronic devices (e.g. pacemakers).

- ▶ Maintain the distances specified by the manufacturer of the pacemakers.
 - Pfeiffer Vacuum recommends a safety distance of **at least 130 mm** between the pacemaker and the product.
- ▶ Avoid the influence of strong magnetic fields by means of magnetic field shielding.

NOTICE**Damage sustained as a result of improper connection**

Improper connection, incorrect polarity or impermissible supply voltage will damage the gauge.

- ▶ Always connect the supply earth (Pin 5) with the earth for the supply unit.
- ▶ Always connect the shielding (Pin 6) with the earth for the supply unit.

Risks during operation

⚠ WARNING**Risk of injury resulting from overpressure in the vacuum system**

Opening tensioning pieces with an overpressure > **1000 hPa** in the vacuum system can lead to injuries as a result of flying parts, and escaping process medium could prove harmful to health.

Elastomer seals in KF connections (e.g. O-rings) are not resistant to pressures > **2500 hPa**. This could prove harmful to health due to escaping process medium.

- ▶ Do not open any tensioning pieces when overpressure is prevalent in the vacuum system.
- ▶ Use suitable tensioning pieces for overpressure.
- ▶ Use tensioning pieces which can only be opened and closed using a tool (e.g. tightening strap-circlip).
- ▶ Use sealing rings with an outer centering ring.



Risks during maintenance

⚠ DANGER

Risk to life due to electric shock

If no earth connection is established, voltage flows become hazardous to the touch and could lead to electronic components sustaining damage.

- ▶ Always tighten the electronic unit with the grub screw.
- ▶ Ensure that the grub screw of the electronic unit has been tightened correctly.

⚠ DANGER

Electric shocks due to moisture penetrating into the device

Moisture that has penetrated into the device results in personal injury through electric shocks.

- ▶ Only operate the device in a dry environment.
- ▶ Operate the device away from fluids and humidity sources.
- ▶ Do not switch on the device if fluid has penetrated into it, instead contact Pfeiffer Vacuum Service.
- ▶ Always disconnect the current supply before cleaning the device.

⚠ WARNING

Health hazard through poisoning from toxic contaminated components or devices

Toxic process media result in contamination of devices or parts of them. During maintenance work, there is a risk to health from contact with these poisonous substances. Illegal disposal of toxic substances causes environmental damage.

- ▶ Take suitable safety precautions and prevent health hazards or environmental pollution by toxic process media.
- ▶ Decontaminate affected parts before carrying out maintenance work.
- ▶ Wear protective equipment.

⚠ WARNING

Health hazards due to cleaning agent

The cleaning agents used cause health hazards.

- ▶ When handling cleaning agents, observe the applicable regulations.
- ▶ Adhere to safety measures regarding handling and disposal of cleaning agents.
- ▶ Be aware of potential reactions with product materials.

NOTICE

Impairment from contamination and damage

Touching the devices or components with bare hands increases the desorption rate and leads to incorrect measurements. Dirt (e.g. dust, fingerprints, etc.) and damage impair the function.

- ▶ During assembly and maintenance work on high or ultra high vacuum systems, always wear clean, lint-free and powder-free laboratory gloves.
- ▶ Only use clean tools.
- ▶ During assembly, ensure for connecting flanges free of grease.
- ▶ Remove protective caps and protective covers from flanges and connections only when necessary.
- ▶ Carry out all work in a well lit area.

NOTICE

Electric flashover from helium

Helium can cause electric flashovers in the unit's electronics which will destroy the electronics.

- ▶ Switch off the unit before carrying out a leak test.
- ▶ Remove the electronic unit before carrying out a leak test.



NOTICE**Damage caused by penetrating moisture**

Penetrating moisture, e.g. through condensation or dripping water, damages the device.

- ▶ Protect the device against moisture penetrating.
- ▶ Only operate the device in a clean and dry environment.
- ▶ Operate the device away from fluids and humidity sources.
- ▶ Take special precautions if there is a risk of dripping water.
- ▶ Do not switch on the device if fluid has penetrated into it, instead contact the Pfeiffer Vacuum Service Center.

NOTICE**Damage caused by unsuitable cleaning agents**

Unsuitable cleaning agents damage the product.

- ▶ Do not use solvents as they attack the surface.
- ▶ Do not use any aggressive or abrasive cleaning agents.

Risks when shipping**⚠ WARNING****Risk of poisoning from contaminated products**

Where products that contain harmful substances are shipped for maintenance or repair purposes, the safety of service personnel is at risk.

- ▶ Comply with the instructions for safe shipping.

Risks during disposal**⚠ CAUTION****Health hazard caused by environmentally hazardous substances**

Products, operating fluid, electric components, calibration gas residues (for example from test leaks) or similar pose health hazards.

- ▶ Dispose of the environmentally hazardous substances in accordance with local regulations.
- ▶ Dispose of calibration gas and test leaks in accordance with local regulations.

2.3 Safety precautions

The product is designed according to the latest technology and recognized safety engineering rules. Nevertheless, improper use can result in danger to operator all third party life and limb, and product damage and additional property damage.

**Duty to provide information on potential dangers**

The product holder or user is obliged to make all operating personnel aware of dangers posed by this product.

Every person who is involved in the installation, operation or maintenance of the product must read, understand and adhere to the safety-related parts of this document.

**Infringement of conformity due to modifications to the product**

The Declaration of Conformity from the manufacturer is no longer valid if the operator changes the original product or installs additional equipment.

- Following the installation into a system, the operator is required to check and re-evaluate the conformity of the overall system in the context of the relevant European Directives, before commissioning that system.

Meet fundamental safety measures

1. When handling the gases and contaminated parts used, observe the applicable guidelines.
2. Observe the protective measures.



3. Observe the safety guidelines specified in this document.
 - All work is only permissible when observing the relevant guidelines and adhering to the protective measures.
4. Inform yourself about any contamination before starting work.
5. Pass on safety instructions to all other users.

2.4 Proper use

The FullRange gauge provides a vacuum measurement of gases within the range of 5×10^{-9} up to 1000 hPa.

The gauge can **not** be used for the measurement of highly flammable or combustible gases in the mixture with an oxidizing agent (e.g. atmospheric oxygen) within the explosion limits.

The gauge can be operated with a Pfeiffer Vacuum total pressure measuring and control unit, or with an evaluation unit provided by the customer.

Using the product according to its intended purpose

1. Install, operate and maintain the product only in accordance with these operating instructions.
2. Comply with the application limits.
3. Observe the technical data.

2.5 Foreseeable improper use

Improper use of the product invalidates all warranty and liability claims. Any use that is counter to the purpose of the product, whether intentional or unintentional, is regarded as misuse, in particular:

- Use outside the mechanical and electrical application limits (technical data)
- Use with corrosive or explosive media, if this is not explicitly permitted
- Use outdoors
- Use after technical changes (on the inside or the outside of the product)
- Use with replacement or accessory parts that are unsuitable or are not approved

2.6 Responsibilities and warranty

Pfeiffer Vacuum shall assume no responsibilities and warranty if the operating company or a third party:

- disregards this document.
- does not use the product for its intended purpose.
- carries out any modifications to the product (conversions, changes, maintenance work, etc.) that are not listed in the corresponding operating instructions.
- operates the product with accessories that are not listed in the corresponding operating instructions.

The operator is responsible for the process media used.

2.7 Owner requirements

Safety-conscious working

1. Only operate the product in a technically flawless state.
2. Operate the product in line with its intended purpose, safety and hazard-conscious and only in compliance with these operating instructions.
3. Fulfill the following instructions and monitor the observation of the following instructions:
 - Proper use
 - Generally applicable safety instructions and accident prevention regulations
 - International, national and locally applicable standards and guidelines
 - Additional product-related guidelines and regulations
4. Only use original parts or parts approved by Pfeiffer Vacuum.
5. Keep the operating instructions available at the place of installation.
6. Ensure personnel qualification.



2.8 Personnel qualification

The work described in this document may only be carried out by persons who have appropriate professional qualifications and the necessary experience or who have completed the necessary training as provided by Pfeiffer Vacuum.

Training people

1. Train the technical personnel on the product.
2. Only let personnel to be trained work with and on the product when under the supervision of trained personnel.
3. Only allow trained technical personnel to work with the product.
4. Before starting work, make sure that the commissioned personnel have read and understood these operating instructions and all applicable documents, in particular the safety, maintenance and repair information.

2.8.1 Ensuring personnel qualification

Specialist for mechanical work

Only a trained specialist may carry out mechanical work. Within the meaning of this document, specialists are people responsible for construction, mechanical installation, troubleshooting and maintenance of the product, and who have the following qualifications:

- Qualification in the mechanical field in accordance with nationally applicable regulations
- Knowledge of this documentation

Specialist for electrotechnical work

Only a trained electrician may carry out electrical engineering work. Within the meaning of this document, electricians are people responsible for electrical installation, commissioning, troubleshooting, and maintenance of the product, and who have the following qualifications:

- Qualification in the electrical engineering field in accordance with nationally applicable regulations
- Knowledge of this documentation

In addition, these individuals must be familiar with applicable safety regulations and laws, as well as the other standards, guidelines, and laws referred to in this documentation. The above individuals must have an explicitly granted operational authorization to commission, program, configure, mark, and earth devices, systems, and circuits in accordance with safety technology standards.

Trained individuals

Only adequately trained individuals may carry out all works in other transport, storage, operation and disposal fields. Such training must ensure that individuals are capable of carrying out the required activities and work steps safely and properly.

2.8.2 Personnel qualification for maintenance and repair



Advanced training courses

Pfeiffer Vacuum offers advanced training courses to maintenance levels 2 and 3.

Adequately trained individuals are:

- **Maintenance level 1**
 - Customer (trained specialist)
- **Maintenance level 2**
 - Customer with technical education
 - Pfeiffer Vacuum service technician
- **Maintenance level 3**
 - Customer with Pfeiffer Vacuum service training
 - Pfeiffer Vacuum service technician

2.8.3 Advanced training with Pfeiffer Vacuum

For optimal and trouble-free use of this product, Pfeiffer Vacuum offers a comprehensive range of courses and technical trainings.

For more information, please contact [Pfeiffer Vacuum technical training](#).

2.9 Operator requirements

Observing relevant documents and data

1. Read, observe and follow this operating instruction and the work instructions prepared by the operating company, in particular the safety and warning instructions.
2. Install, operate and maintain the product only in accordance with these operating instructions.
3. Carry out all work only on the basis of the complete operating instructions and applicable documents.
4. Comply with the application limits.
5. Observe the technical data.
6. Please contact the Pfeiffer Vacuum Service Center if your questions on operation or maintenance of the product are not answered by these operating instructions.
 - You can find information in the [Pfeiffer Vacuum service area](#).



3 Transportation and storage

NOTICE

Damage caused by incorrect transportation

Transportation in unsuitable packaging, or failure to install all transport locks, can damage the product.

- ▶ Comply with the instructions for safe transportation.

NOTICE

Damage caused by improper storage

Improper storage will lead to damage to the product.

Static charging, moisture, etc. lead to defects on the electronic components.

- ▶ Comply with the instructions for safe storage.

Transporting the product safely

1. Observe the weight of the product.
2. Where possible, always transport or ship the product in the original packaging.
3. Always use dense and impact-proof packaging for the product.
4. Remove the existing protective cover and transport protections only immediately prior to installation.
5. Reattach transport locks and transport protections prior to each transport.

Storing the product safely

1. Store the product in a cool, dry, dust-free place, where it is protected against impacts and mechanical vibration.
2. Always use dense and impact-proof packaging for the product.
3. Where possible, store the product in the original packaging.
4. Store electronic components in antistatic packaging.
5. Maintain the permissible storage temperature.
6. Avoid extreme fluctuations of the ambient temperature.
7. Avoid high air humidity.
8. Seal connections with the original protective caps.
9. Protect the product with the original transport protections (where available).



4 Product description

4.1 Identifying the product

You will need all the data from the rating plate to safely identify the product when communicating with Pfeiffer Vacuum.

Recording rating plate data

1. Read the data on the product rating plate.
2. Record this data.
3. Always have all rating plate specifications to hand.

4.2 Scope of delivery

The shipment includes the following parts:

- Gauge
- Brief instructions

Unpacking the product and checking completeness of the shipment

1. Unpack the product.
2. Remove the transport fasteners, transport protection etc.
3. Store the transport fasteners, transport protection etc. in a safe place.
4. Check that the shipment is complete.
5. Ensure that no parts are damaged.

4.3 Function

The gauge has 2 measuring systems:

- Pirani measuring system
- Cold cathode measuring system functioning to the principle of the inverted magnetron

The Pirani measuring circuit is switched on at all times. The cold cathode measuring circuit controlled by the Pirani measuring circuit is only activated by the gauge when the pressures reach $p < 1 \times 10^{-2}$ hPa. Specific linking of both measuring systems ensures that the measuring systems generally behave as one standardized measuring system for the user. The measuring signal is logarithmically dependent on the pressure across the entire measuring range.

The gauge applies the optimum measuring configuration for the respective pressure range:

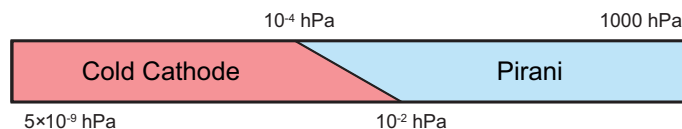

Fig. 1: Measuring configuration



5 Installation

5.1 Establishing the vacuum connection

⚠ DANGER

Risk to life due to electric shock

An improperly earthed product is potentially fatal in the event of a fault.

- ▶ Connect the product galvanically with the earthed vacuum chamber.
- ▶ Ensure that the connection complies with the requirements of a protective bonding according to EN 61010. (CF and VCR connections comply with this requirement.)
- ▶ Use electrically conductive centering rings and circlips for KF connections.

⚠ DANGER

Risk to life due to electric shock

If no earth connection is established, voltage flows become hazardous to the touch and could lead to electronic components sustaining damage.

- ▶ Always tighten the electronic unit with the grub screw.
- ▶ Ensure that the grub screw of the electronic unit has been tightened correctly.

⚠ WARNING

Risk of injury resulting from overpressure in the vacuum system

Opening tensioning pieces with an overpressure $> 1000 \text{ hPa}$ in the vacuum system can lead to injuries as a result of flying parts, and escaping process medium could prove harmful to health.

Elastomer seals in KF connections (e.g. O-rings) are not resistant to pressures $> 2500 \text{ hPa}$. This could prove harmful to health due to escaping process medium.

- ▶ Do not open any tensioning pieces when overpressure is prevalent in the vacuum system.
- ▶ Use suitable tensioning pieces for overpressure.
- ▶ Use tensioning pieces which can only be opened and closed using a tool (e.g. tightening strap-circlip).
- ▶ Use sealing rings with an outer centering ring.

NOTICE

Impairment from contamination and damage

Touching the devices or components with bare hands increases the desorption rate and leads to incorrect measurements. Dirt (e.g. dust, fingerprints, etc.) and damage impair the function.

- ▶ During assembly and maintenance work on high or ultra high vacuum systems, always wear clean, lint-free and powder-free laboratory gloves.
- ▶ Only use clean tools.
- ▶ During assembly, ensure for connecting flanges free of grease.
- ▶ Remove protective caps and protective covers from flanges and connections only when necessary.
- ▶ Carry out all work in a well lit area.

NOTICE

Electric flashover from helium

Helium can cause electric flashovers in the unit's electronics which will destroy the electronics.

- ▶ Switch off the unit before carrying out a leak test.
- ▶ Remove the electronic unit before carrying out a leak test.



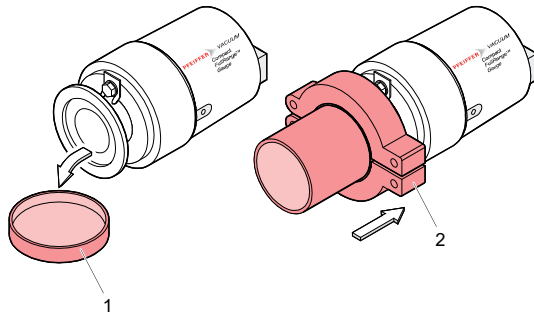

Fig. 2: Establishing the vacuum connection

- 1 Protective cap
- 2 Tensioning piece

Procedure

1. Ensure that the permissible operating temperature of the gauge is not exceeded.
2. Observe space required for the electrical connection (e.g. permissible bending radii for the cables).
3. Fit the gauge eliminating any exposure to vibrations where possible.
 - Vibrations at the gauge generally lead to deviations in the measured values.
4. Ensure a suitable mounting orientation.
5. Recommendation: Fit the gauge with horizontal to upright mounting orientation.
 - This will prevent condensate and particles from accumulating in the measurement chamber.
6. If necessary, fit a seal with centering ring and filter in the event of potential contamination during use, as well as to protect the measuring system against contamination.
7. Recommendation: Remove the magnetic unit of the gauge temporarily if flange-mounting is only possible with the magnetic unit removed.
 - This will facilitate installation of the CF flange connection.
8. Ensure that both trimming potentiometers of the gauge can be easily accessed with a screwdriver once fitted.
9. Remove the protective cap and store in a safe place.
10. Connect the gauge to the vacuum system.
11. If it was previously necessary to remove the magnetic unit of the gauge, install the electronic unit once again.

5.2 Removing/installing the magnetic unit

NOTICE

Impairment from contamination and damage

Touching the devices or components with bare hands increases the desorption rate and leads to incorrect measurements. Dirt (e.g. dust, fingerprints, etc.) and damage impair the function.

- ▶ During assembly and maintenance work on high or ultra high vacuum systems, always wear clean, lint-free and powder-free laboratory gloves.
- ▶ Only use clean tools.
- ▶ During assembly, ensure for connecting flanges free of grease.
- ▶ Remove protective caps and protective covers from flanges and connections only when necessary.
- ▶ Carry out all work in a well lit area.

Removal of the magnetic unit should facilitate the fitting of the gauge.



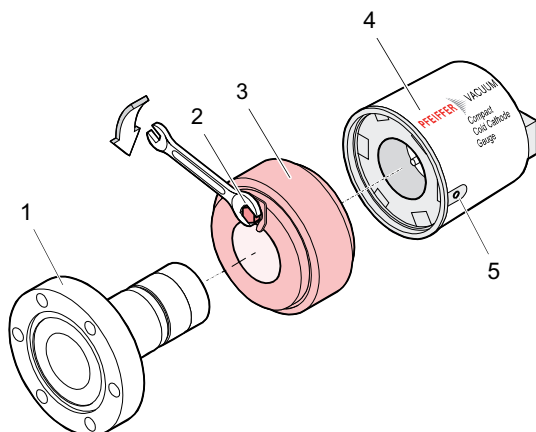

Fig. 3: Removing/installing the magnetic unit (recommended for CF-F)

- | | |
|-----------------------|-------------------|
| 1 Measurement chamber | 4 Electronic unit |
| 2 Hexagon head screw | 5 Grub screw |
| 3 Magnetic unit | |

Removing the magnetic unit

Required tools

- Allen key (1.5 WAF)
- Open-end wrench (7 WAF)

1. Loosen the grub screw on the side of the electronic unit.
2. Remove the electronic unit **without exerting any rotary movement**.
3. Loosen the hexagon head screw on the magnetic unit.
4. Remove the magnetic unit.
 - Separation of the magnetic unit and measurement chamber is made more difficult due to the effect of magnetic force and the tendency for them to tilt easily.

Installing the magnetic unit

Required tools

- Allen key (1.5 WAF)
- Open-end wrench (7 WAF)

1. Install the magnetic unit.
 - Installing the magnetic unit is made more difficult due to the effect of magnetic force and the tendency for it to tilt easily.
2. Fasten the hexagon head screw on the magnetic unit.
3. Carefully install the electronic unit.
 - The male connector of the Pirani element must engage in the corresponding opening of the electronic unit.
4. Push the electronic unit as far as the stop.
5. Secure the grub screw on the side of the electronic unit.

5.3 Establishing the electrical connection

⚠ DANGER

Danger to life due to dangerous contact voltage

Voltages above 30 V (AC) or 60 V (DC) are considered dangerous in accordance with EN 61010. If you come into contact with dangerous contact voltage, this can result in injury through electric shocks or even death.

- ▶ Only connect the product to devices which meet the following criteria:
 - Requirements of the earthed protective extra-low voltage (PELV)
 - Limited power source (LPS) Class 2
- ▶ Secure the line to the product.
 - Pfeiffer Vacuum measuring and control equipment complies with this requirement.



NOTICE

Damage sustained as a result of improper connection

Improper connection, incorrect polarity or impermissible supply voltage will damage the gauge.

- ▶ Always connect the supply earth (Pin 5) with the earth for the supply unit.
- ▶ Always connect the shielding (Pin 6) with the earth for the supply unit.

To operate the gauge with a Pfeiffer Vacuum total pressure measuring and control unit, you will require a corresponding measurement cable from the [ActiveLine Accessories](#). Otherwise, you can also manufacture a measurement cable specifically for this purpose.

Establishing the electrical connection

Required tool

- Torque wrench ($\leq 0.2 \text{ Nm}$)

Required material

- Measurement cable (as an accessory or manufactured for this purpose)

1. Connect the measurement cable to the gauge.
2. Tighten the locking screw on the Hirschmann cable socket.
 - Tightening torque: $\leq 0.2 \text{ Nm}$

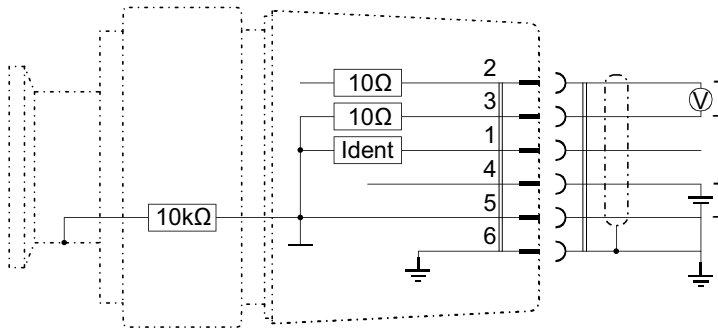

Fig. 4: Connection diagram

- | | |
|--------------------|------------------------|
| 1 Identification | 4 Supply |
| 2 Measuring signal | 5 Supply earth (GND) |
| 3 Signal earth | 6 Screening, shielding |

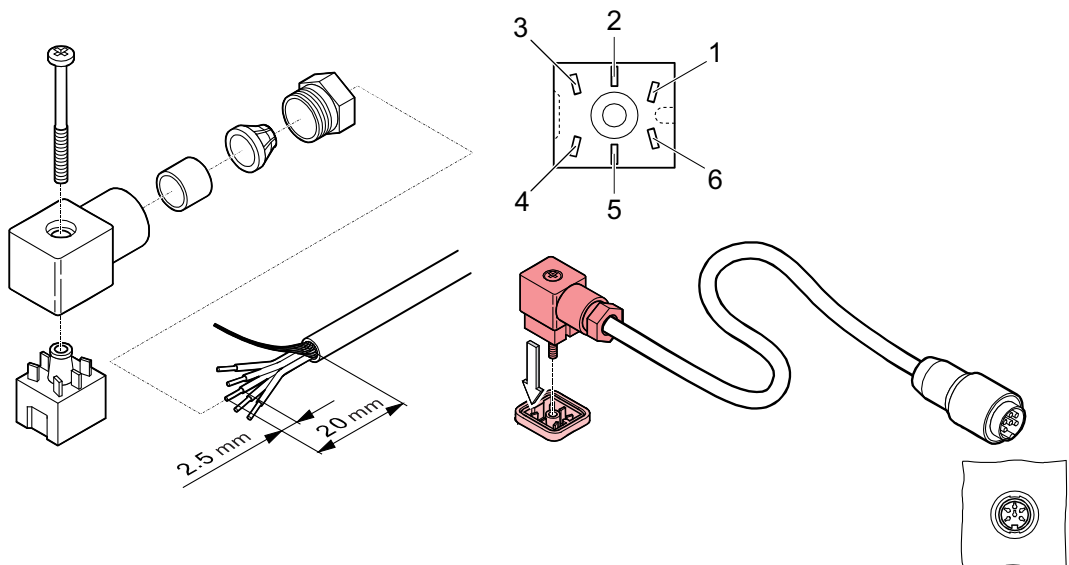

Fig. 5: Measurement cable and Hirschmann cable socket



Manufacturing a measurement cable

1. Observe the following steps to ensure optimum signal quality, whereby ground loops, differences in potential or EMC will influence the measuring signal.
 - Use a cable with braided shield and metallic connector housing.
 - Additional information regarding measurement cable type and conductor cross-sections can be obtained in the technical data.
 - Connect the supply earth directly with the protective earth for power supply pack.
 - Use a differential measuring input (separate signal earth and supply earth).
 - Ensure that the potential difference between supply earth and housing is ≤ 6 V (surge protection).
2. Assemble the Hirschmann cable socket.

Assembling the Hirschmann cable socket**Accessories required**

- Hirschmann cable socket
1. Prepare the Hirschmann cable socket as shown in the "Measurement cable and Hirschmann cable socket" diagram.
 2. Solder in the connection cable as prescribed in the connection diagram.
 3. Assemble the Hirschmann cable socket.



6 Operation

Once the supply voltage has been established, the measuring signal is available at the electrical connection (Pins 2 and 3).

Operating the gauge

1. Respect the stabilization period of at least 10 minutes.
2. Respect the relation between measuring signal and pressure.
3. Recommendation: Leave the gauge switched on at all times, regardless of the prevalent pressure.

6.1 Status display



Fig. 6: Light emitting diode (LED)

1 Green LED

Pressure	LED	Operating mode	Identification
$p > 1 \times 10^{-2}$ hPa	Off	Pirani operation	11.1 k Ω (Pirani)
$p < 1 \times 10^{-2}$ hPa	lights up	Pirani operation (cold cathode measuring system not ignited)	11.1 k Ω (Pirani)
		Combined operation	9.1 k Ω (combination)

Tbl. 4: Operating modes

The identification output shows the respective operating state of the gauge. As long as the cold cathode measuring circuit has not ignited, the signal output issues solely the Pirani measured value once again. (if $p < 5 \times 10^{-4}$ hPa: display "Pirani underrange").



6.2 Relation: measuring signal and pressure

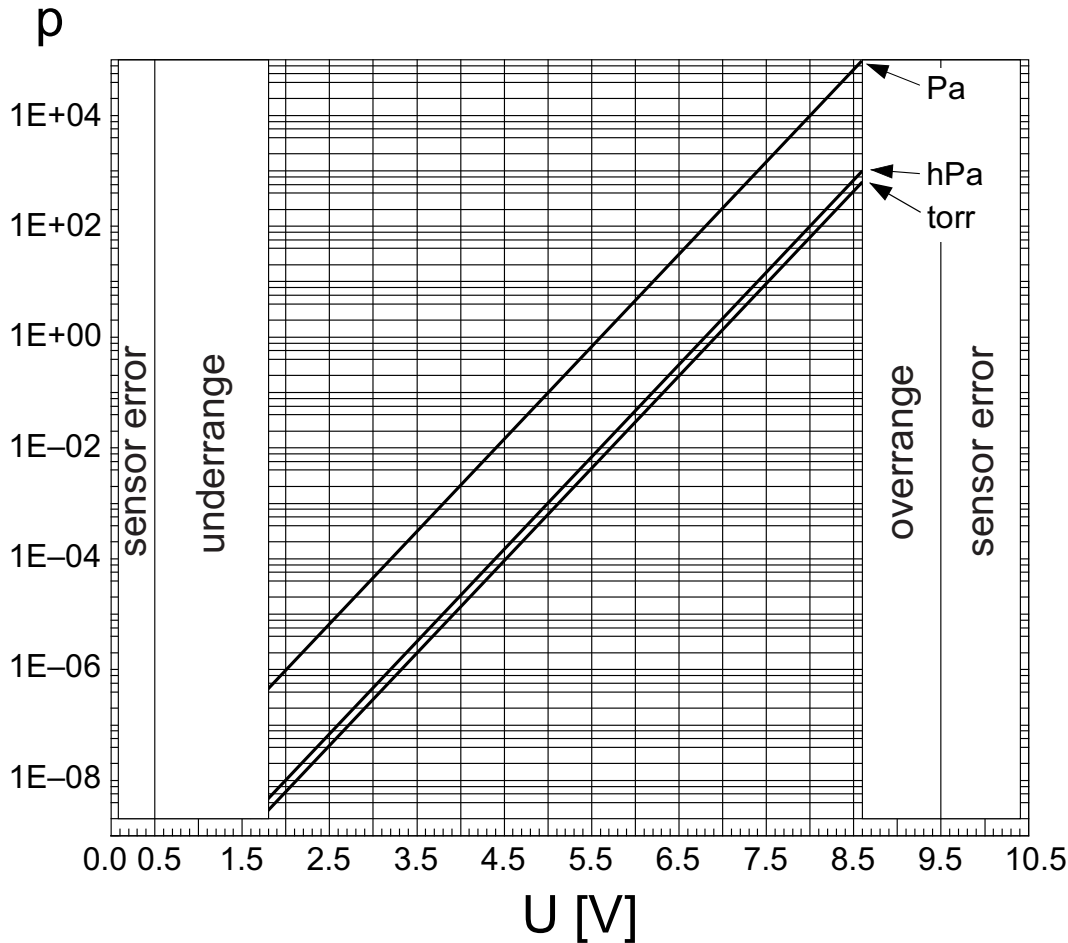

Fig. 7: Relation: measuring signal and pressure

p Pressure U Measuring signal [V]

Calculation

Validity range:

- $5 \times 10^{-9} \text{ hPa} < p < 1000 \text{ hPa}$
- $3.8 \times 10^{-9} \text{ Torr} < p < 750 \text{ Torr}$
- $5 \times 10^{-7} \text{ Pa} < p < 1 \times 10^5 \text{ Pa}$

Formula: $p = 10^{(1.667 \times U - d)}$ ↔ $U = c + 0.6 \times \log_{10} p$

Measuring signal (U)	Pressure (p)	Constant (c) ¹⁾	Constant (d) ²⁾
[V]	[hPa]	6.8	11.33
	[mbar]		
	[Torr]	6.875	11.46
	[micron]	5.075	8.458
	[Pa]	5.6	9.333

Tbl. 5: Constants

1) Dependent upon unit of pressure
 2) Dependent upon unit of pressure

Measuring signal (U)	Pressure (p)		
	[hPa]	[Torr]	[Pa]
< 0.5	Sensor error		
0.5 – 1.82	Underrange		
1.82	5.0×10^{-9}	3.8×10^{-9}	5.0×10^{-7}
2.0	1.0×10^{-8}	7.5×10^{-9}	1.0×10^{-6}
2.6	1.0×10^{-7}	7.5×10^{-8}	1.0×10^{-5}
3.2	1.0×10^{-6}	7.5×10^{-7}	1.0×10^{-4}
3.8	1.0×10^{-5}	7.5×10^{-6}	1.0×10^{-3}
4.4	1.0×10^{-4}	7.5×10^{-5}	1.0×10^{-2}
5.0	1.0×10^{-3}	7.5×10^{-4}	0.1
5.6	1.0×10^{-2}	7.5×10^{-3}	1.0
6.2	0.1	7.5×10^{-2}	10
6.8	1.0	0.75	100
7.4	10	7.5	1000
8.0	100	75	1.0×10^4
8.6	1000	750	1.0×10^5
8.6 – 9.5	Overrange		
9.5 – 10.5	Sensor error (Pirani faulty)		

Tbl. 6: Conversion table

6.3 Gas type dependence

The measuring signal is gas type dependent. The characteristics apply for nitrogen (N₂), oxygen (O₂), dry air and carbon monoxide (CO). When operating the gauge with a Pfeiffer Vacuum total pressure measuring and control unit (TPG), you can enter a calibration factor to adjust the displayed measured value.

Pressure range > 10⁻² hPa (solely Pirani operation)

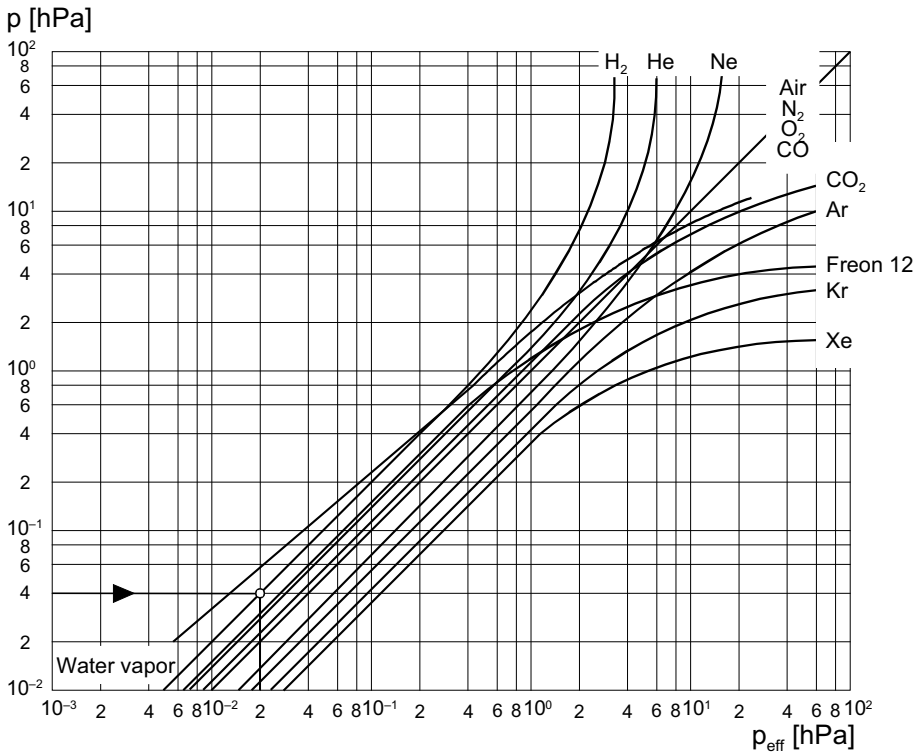

Fig. 8: Pressure range > 10⁻² hPa, solely Pirani operation



Pressure range from 10⁻⁶ up to 0.1 hPa

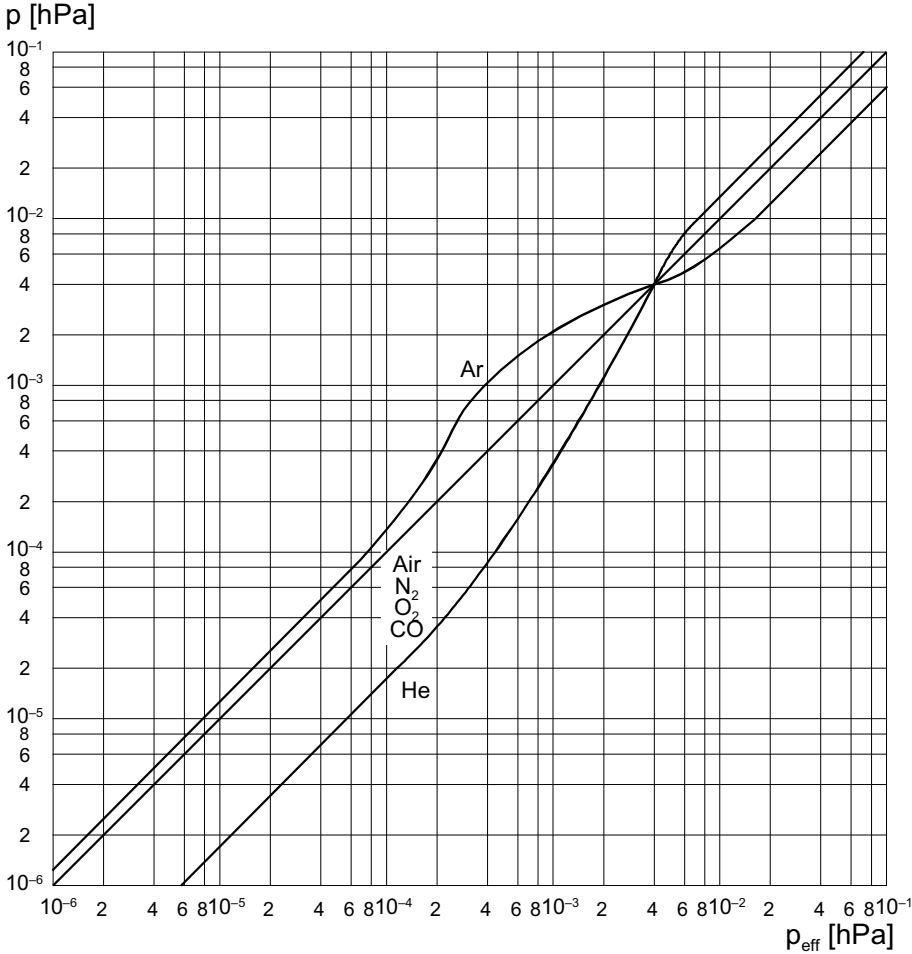

Fig. 9: Pressure range from 10⁻⁶ up to 0.1 hPa

Calibration factors

Within the pressure range < 10⁻⁵ hPa, the display is linear. For other gases as air, you can determine the pressure by applying a simple conversion:

Calculation: $P_{eff} = C \times p$

- **P_{eff}**
Effective pressure
- **C**
Calibration factor
- **p**
Displayed pressure
(gauge calibrated for air)

i **Gas mixture**
 Mixtures of gases and vapors are often involved here. In such cases, precise measuring is only possible using partial pressure measurement instruments, for example a quadrupole mass spectrometer.

Gas type	Calibration factor (C)
Air, oxygen (O ₂), carbon monoxide (CO), nitrogen (N ₂)	1.0
Hydrogen (H ₂)	2.4
Helium (He)	5.9

The calibration factors provided are mean values.

Gas type	Calibration factor (C)
Neon (Ne)	4.1
Argon (Ar)	0.8
Krypton (Kr)	0.5
Xenon (Xe)	0.4

The calibration factors provided are mean values.

Tbl. 7: Calibration factors for the pressure range <math> < 10^{-5}</math> hPa

6.4 Ignition delay

Cold cathode measuring systems have an ignition delay upon activation. This ignition delay is longer for lower pressures and is typically in clean, degassed units:

- 10^{-5} hPa approx. 1 second
- 10^{-7} hPa approx. 20 seconds
- 5×10^{-9} hPa approx. 2 minutes



Activation with pressure $p < 3 \times 10^{-9}$ hPa

When activating the gauge with a pressure $p < 3 \times 10^{-9}$ hPa, the gauge will not detect any ignition of the cold cathode system. The gauge displays "Pirani underrange".



Maintaining operation of the gauge

If continuous operation of the flange-mounted gauge is maintained regardless of pressure range, the ignition delay time of the cold cathode measuring circuit is always negligible (< 1 s), with minimal thermal stabilization effects.

The ignition is a static process, for which even minimal depositions can have a major influence on the inner surfaces. As long as the cold cathode measuring circuit has not ignited, the signal output issues solely the Pirani measured value once again (display "Pirani underrange" for pressures $p < 5 \times 10^{-4}$ hPa). The identification output signals solely Pirani operation.

6.5 Contamination



Warranty

Malfunctioning of the equipment as a direct result of contamination or wear, as well as wear parts (e.g. ignition aid) is not covered by the warranty.

Contamination of the gauge is dependent upon

- pressure in the vacuum chambers
- the type of process media
- potentially existing or newly accumulated contamination or its partial pressure (e.g. vapors, process particles etc.)
- the operating time

Continuous operation in the range between 10^{-4} hPa and 10^{-2} hPa can lead to major contamination, and thus reduced service life and shorter maintenance intervals. With consistently low pressures ($p < 1 \times 10^{-6}$ hPa), service lives of > 1 year can be attained before cleaning is required.

Contamination of the gauge generally leads to deviations in the measured values:

- Within the range of **high pressures** (1×10^{-3} hPa to 0.1 hPa), the pressure displayed is too high (contamination of the Pirani element). The Pirani measurement system must be recalibrated.
- Within the range of **low pressures** ($< 1 \times 10^{-3}$ hPa), the pressure displayed is generally too low (contamination of the cold cathode system). Excessive contamination will cause instabilities (separation of layers in the measurement chamber). This can lead to short circuiting. Complete quenching of the gas discharge is also possible in the event of contamination resulting from insulating layers (display: "underrange").



Influencing the degree of contamination

It is possible to influence the level of contamination to a certain extent. Particular care should be afforded for vapors which are separated in the plasma (e.g. from the cold cathode measuring system).

1. Implement geometric safety measures (screening sheets, bends) for particles propagated in a straight line.
2. Choose a flange position in which the partial pressure of the contamination is at a minimum.
3. Switch off the gauge during the presence of separating vapors.

or

Seal off the gauge by means of a valve during the presence of separating vapors.



7 Disassembly

⚠ DANGER

Risk to life due to electric shock

An improperly earthed product is potentially fatal in the event of a fault.

- ▶ Connect the product galvanically with the earthed vacuum chamber.
- ▶ Ensure that the connection complies with the requirements of a protective bonding according to EN 61010. (CF and VCR connections comply with this requirement.)
- ▶ Use electrically conductive centering rings and circlips for KF connections.

⚠ WARNING

Risk of injury resulting from overpressure in the vacuum system

Opening tensioning pieces with an overpressure > 1000 hPa in the vacuum system can lead to injuries as a result of flying parts, and escaping process medium could prove harmful to health.

Elastomer seals in KF connections (e.g. O-rings) are not resistant to pressures > 2500 hPa. This could prove harmful to health due to escaping process medium.

- ▶ Do not open any tensioning pieces when overpressure is prevalent in the vacuum system.
- ▶ Use suitable tensioning pieces for overpressure.
- ▶ Use tensioning pieces which can only be opened and closed using a tool (e.g. tightening strap-circlip).
- ▶ Use sealing rings with an outer centering ring.

NOTICE

Impairment from contamination and damage

Touching the devices or components with bare hands increases the desorption rate and leads to incorrect measurements. Dirt (e.g. dust, fingerprints, etc.) and damage impair the function.

- ▶ During assembly and maintenance work on high or ultra high vacuum systems, always wear clean, lint-free and powder-free laboratory gloves.
- ▶ Only use clean tools.
- ▶ During assembly, ensure for connecting flanges free of grease.
- ▶ Remove protective caps and protective covers from flanges and connections only when necessary.
- ▶ Carry out all work in a well lit area.

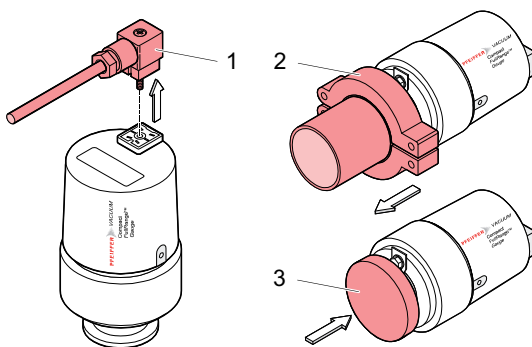

Fig. 10: Disassembling the gauge

- | | |
|---------------------|------------------|
| 1 Measurement cable | 3 Protective cap |
| 2 Tensioning piece | |

Disassembling the gauge

1. Vent the vacuum system.
2. Switch off the gauge.
3. Loosen the locking screw of the Hirschmann cable socket on the gauge.
4. Disconnect the measurement cable from the gauge.



5. Recommendation: Remove the magnetic unit of the gauge temporarily if disassembling is only possible with the magnetic unit removed.
 - This will facilitate disassembling the CF flange connection.
6. Disconnect the gauge from the vacuum system.
7. Put the protective cap on the connection flange.

8 Maintenance



Maintenance in the Pfeiffer Vacuum Service Center

Pfeiffer Vacuum offers a complete maintenance service for all products.

Pfeiffer Vacuum recommends: Contact your Pfeiffer Vacuum Service Center to arrange the maintenance of defective products and components.



Cleaning in the Pfeiffer Vacuum Service Center

Pfeiffer Vacuum recommends: Contact your nearest Pfeiffer Vacuum Service Center to arrange the cleaning of heavily-soiled products and components.



Loss of warranty claims

The following will result in the loss of the warranty:

- Damage to or removal of a closure seal
- Opening the device during the warranty period

Contact the Pfeiffer Vacuum Service Center in the event of process-related shorter maintenance intervals.



First read through the sections completely

Read the section with the work instructions through completely first before you commence with work.

8.1 Calibrating the gauge

Pfeiffer Vacuum has calibrated the gauge to standard values at the factory.

The dominant cold cathode measuring circuit for the low pressure range ($< 1 \times 10^{-3}$ hPa) has been calibrated by Pfeiffer Vacuum to a fixed value at the factory. It is possible, however, to readjust the Pirani measuring circuit. Calibration has a negligible influence on the pressure range between approximately 10^{-2} hPa and 10^2 hPa.

Preparing for calibration

1. Perform a calibration at regular intervals.
 - Utilization in other climatic conditions, long-term operation, extreme temperatures, a different mounting orientation and aging or contamination can lead to a zero point shift in the Pirani measuring circuit. This will in turn necessitate recalibration or cleaning.
2. Perform the calibration under the same, consistent ambient conditions and with the same mounting orientation as normally used for the gauge.
3. Inspect any fitted seal with centering ring and filter for contamination.
4. Replace any fitted seal with centering ring and filter wherever these parts are contaminated or damaged.
5. Perform commissioning of the gauge.

You may now perform a calibration.



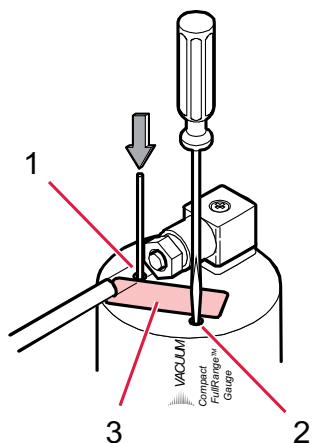

Fig. 11: Calibrating the gauge (HV)

- | | |
|----------------------|----------------------------|
| 1 Button | 3 Rating plate (rotatable) |
| 2 Potentiometer "HV" | |

Performing an HV calibration

Required tools

- Screwdriver (1.5 mm)
- Stylus (max. Ø 3 mm)

Required aids

- Control unit or voltmeter
1. Activate the gauge, as near as possible to the subsequent operating position.
 2. Evacuate the vacuum system to $p \ll 10^{-4}$ hPa.
 3. Wait for at least 10 minutes.
 4. Turn the rating plate in an anticlockwise direction up to the stop.
 5. Press the button using a stylus, while simultaneously calibrating the "HV" potentiometer with the control unit or with the voltmeter.
 - Control unit: 5×10^{-4} hPa
 - Voltmeter: 4.2 V
 6. Rotate the potentiometer around a 1/3 of a turn in an anticlockwise direction.
 7. Turn the rating plate back into its original position.

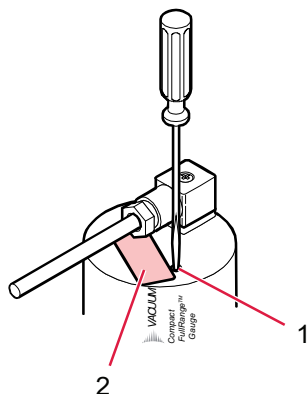

Fig. 12: Calibrating the gauge (ATM)

- | | |
|-----------------------|----------------------------|
| 1 Potentiometer "ATM" | 2 Rating plate (rotatable) |
|-----------------------|----------------------------|

Performing an ATM calibration

Required tools

- Screwdriver (1.5 mm)
- Stylus (max. Ø 3 mm)

Required aids

- Control unit or voltmeter
1. Activate the gauge, as near as possible to the subsequent operating position.
 2. Allow the gauge to run for at least 10 minutes at atmospheric pressure.
 3. Turn the rating plate in a clockwise direction up to the stop.
 4. Calibrate the "ATM" potentiometer with the control unit or voltmeter.
 - Control unit: 1×10^3 hPa
 - Voltmeter: 8.6 V
 5. Turn the rating plate back into its original position.

8.2 Disassembling the gauge

NOTICE

Impairment from contamination and damage

Touching the devices or components with bare hands increases the desorption rate and leads to incorrect measurements. Dirt (e.g. dust, fingerprints, etc.) and damage impair the function.

- ▶ During assembly and maintenance work on high or ultra high vacuum systems, always wear clean, lint-free and powder-free laboratory gloves.
- ▶ Only use clean tools.
- ▶ During assembly, ensure for connecting flanges free of grease.
- ▶ Remove protective caps and protective covers from flanges and connections only when necessary.
- ▶ Carry out all work in a well lit area.

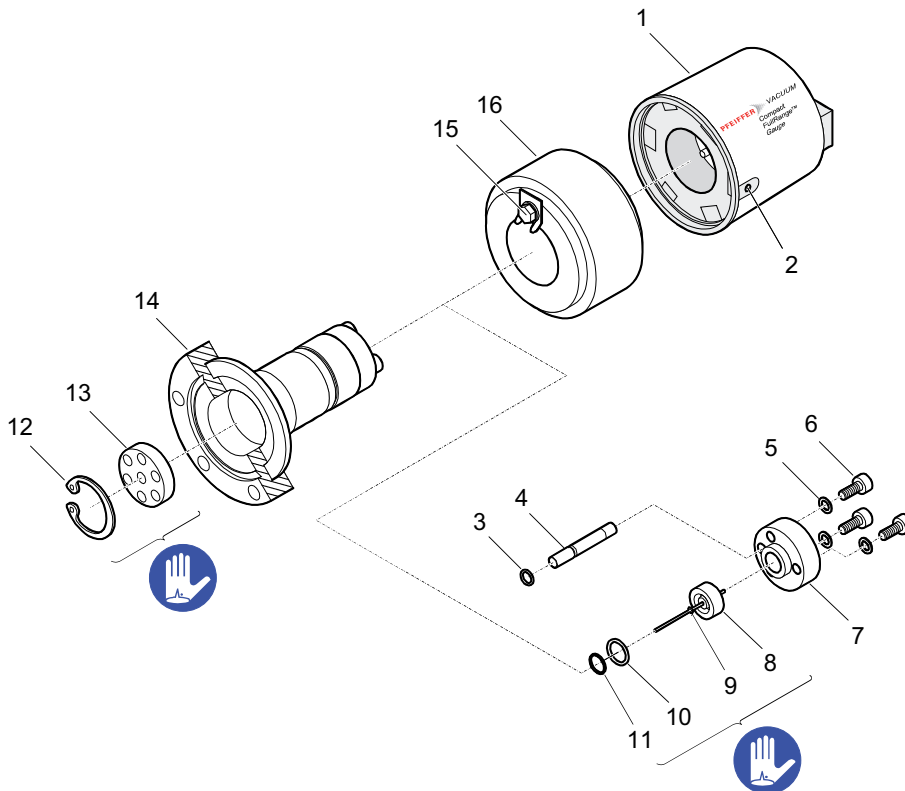

Fig. 13: Individual parts

- | | |
|---------------------------------------|-----------------------------|
| 1 Electronic unit | 9 Ignition aid |
| 2 Grub screw | 10 FPM seal (anode bushing) |
| 3 FPM seal (Pirani measuring element) | 11 Inner ring |
| 4 Pirani measuring element | 12 Circlip |
| 5 Lock washer (3x) | 13 Polarity insert |
| 6 Allen head screw (3x) | 14 Measurement chamber |
| 7 Compression piece | 15 Hexagon head screw |
| 8 Anode | 16 Magnetic unit |



Disassembling the gauge

Required tools

- Allen key (1.5 WAF)
 - Allen key (3.0 WAF)
 - Open-end wrench (7 WAF)
 - Pincers for circlip
 - Tweezers
1. Disconnect the gauge from the vacuum system.
 2. Loosen the grub screw on the side of the electronic unit.
 3. Remove the electronic unit **without exerting any rotary movement**.
 - The hood of the electronic unit cannot be removed.
 4. Loosen the hexagon head screw on the magnetic unit.
 5. Remove the magnetic unit.
 - Separation of the magnetic unit and measurement chamber is made more difficult due to the effect of magnetic force and the tendency for them to tilt easily.
 6. Remove the circlip and the polarity insert from the measurement chamber.
 7. Remove the allen head screws and the lock washers from the rear of the measurement chamber.
 8. Remove the following one after the other affording the appropriate care, and without applying any force to the Pirani measuring element
 - the compression piece,
 - the complete anode,
 - the FPM seal (anode bushing) including the inner ring,
 - the Pirani measuring element with the FPM seal.

8.3 Cleaning of components

DANGER

Electric shocks due to moisture penetrating into the device

Moisture that has penetrated into the device results in personal injury through electric shocks.

- ▶ Only operate the device in a dry environment.
- ▶ Operate the device away from fluids and humidity sources.
- ▶ Do not switch on the device if fluid has penetrated into it, instead contact Pfeiffer Vacuum Service.
- ▶ Always disconnect the current supply before cleaning the device.

WARNING

Health hazards due to cleaning agent

The cleaning agents used cause health hazards.

- ▶ When handling cleaning agents, observe the applicable regulations.
- ▶ Adhere to safety measures regarding handling and disposal of cleaning agents.
- ▶ Be aware of potential reactions with product materials.

NOTICE

Damage caused by penetrating moisture

Penetrating moisture, e.g. through condensation or dripping water, damages the device.

- ▶ Protect the device against moisture penetrating.
- ▶ Only operate the device in a clean and dry environment.
- ▶ Operate the device away from fluids and humidity sources.
- ▶ Take special precautions if there is a risk of dripping water.
- ▶ Do not switch on the device if fluid has penetrated into it, instead contact the Pfeiffer Vacuum Service Center.



NOTICE**Damage caused by unsuitable cleaning agents**

Unsuitable cleaning agents damage the product.

- ▶ Do not use solvents as they attack the surface.
- ▶ Do not use any aggressive or abrasive cleaning agents.

**Cleaning the measurement chamber**

Pfeiffer Vacuum recommends replacing the Pirani measuring element when cleaning the measurement chamber.

**Replacing the Pirani measuring element**

Pfeiffer Vacuum recommends replacing any heavily contaminated or faulty Pirani measuring elements.

External cleaning of the device**Required consumables**

- Industrial alcohol
- Cloth (soft, lint-free)

1. Always use a cloth soaked in industrial alcohol for external cleaning.
2. Allow the surfaces to dry thoroughly after cleaning.

Cleaning the measurement chamber and polarity insert**Required consumables**

- Polishing cloth (400 grade or Scotch-Brite)
- Industrial alcohol

1. Disassemble the gauge to the degree required.
2. Ensure that all work on the sealing surfaces is performed concentrically.
3. Rub the inside walls of the measurement chamber and polarity insert with the polishing cloth until shiny.
4. Rinse the measurement chamber and polarity insert with industrial alcohol.
5. Allow the parts to dry well.
6. Assemble the gauge again.

Cleaning the anode**Required consumables**

- Polishing cloth (400 grade or Scotch-Brite)
- Industrial alcohol

Required tool

- Tweezers
1. Disassemble the gauge to the degree required.
 2. Remove the old ignition aid with tweezers.
 3. Rub the anode pin with a polishing cloth until shiny.
 - Do not bend the anode.
 - Do not treat the ceramic with mechanical means.
 4. Rinse the anode with industrial alcohol.
 5. Allow the anode to dry well.
 6. Replace the ignition aid.
 7. Assemble the gauge again.

Cleaning the Pirani measuring element**Required consumables**

- Industrial alcohol

Required aids

- Hot air blower (< 150 °C)



Required spare parts

- FPM seal (Pirani measuring element)
 1. Disassemble the gauge to the degree required.
 2. Remove the FPM seal from the Pirani measuring element.
 3. Fill the small tube of the measuring element with industrial alcohol.
 4. Allow sufficient time for the industrial alcohol to take effect.
 5. Drain the industrial alcohol from the small tube.
 6. Allow the small tube to dry well.
 - You can use a hot air blower for this purpose.
 7. Put a new FPM seal on the Pirani measuring element and into the groove provided.
 8. Assemble the gauge again.

8.4 Assembling the gauge

⚠ DANGER**Risk to life due to electric shock**

If no earth connection is established, voltage flows become hazardous to the touch and could lead to electronic components sustaining damage.

- ▶ Always tighten the electronic unit with the grub screw.
- ▶ Ensure that the grub screw of the electronic unit has been tightened correctly.

NOTICE**Impairment from contamination and damage**

Touching the devices or components with bare hands increases the desorption rate and leads to incorrect measurements. Dirt (e.g. dust, fingerprints, etc.) and damage impair the function.

- ▶ During assembly and maintenance work on high or ultra high vacuum systems, always wear clean, lint-free and powder-free laboratory gloves.
- ▶ Only use clean tools.
- ▶ During assembly, ensure for connecting flanges free of grease.
- ▶ Remove protective caps and protective covers from flanges and connections only when necessary.
- ▶ Carry out all work in a well lit area.

NOTICE**Electric flashover from helium**

Helium can cause electric flashovers in the unit's electronics which will destroy the electronics.

- ▶ Switch off the unit before carrying out a leak test.
- ▶ Remove the electronic unit before carrying out a leak test.

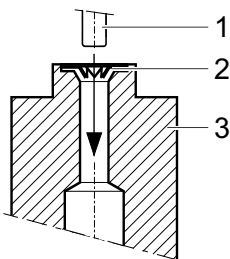

Fig. 14: Mounting tool for the ignition aid

- | | |
|----------------|-----------------|
| 1 Anode | 3 Mounting tool |
| 2 Ignition aid | |

Replacing the ignition aid**Required tool**

- Mounting tool for the ignition aid



Required spare part

- Ignition aid
1. Insert the new ignition aid in the mounting tool.
 2. Carefully push the anode (either new or cleaned) into the ignition aid, in the center, and parallel to the tool axis.
 3. Insert the anode approx. 15 mm.



Positioning the anode

The final positioning will be achieved only after the installation of the anode.

Here you find the individual parts: (see chapter “Disassembling the gauge”, page 34)

Assembling the gauge

Required tools

- Allen key (1.5 WAF)
- Allen key (3.0 WAF)
- Open-end wrench (7 WAF)
- Pincers for circlip
- Mounting tool for the ignition aid
- Tweezers

Required spare parts

- Repair kit BN 846 238 -T

Required consumables

- Dry nitrogen for blowing out
1. Ensure that sealing surfaces, seals and the ceramic (anode) are clean.
 2. Insert the FPM seal (anode bushing) with the inner ring so that it is centric in the measurement chamber.
 3. Carefully insert the anode together with the ignition aid into the measurement chamber.
 4. Put the FPM seal on the Pirani measuring element in the groove provided.
 5. Insert the Pirani measuring element with the fitted FPM seal into the borehole provided.
 6. Carefully fit the compression piece onto the measurement chamber and tighten the Allen head screws and the lock washers evenly, up to the stop.
 7. Push the measurement chamber with anode carefully into the mounting tool, in the center, and parallel to the tool axis up to the stop.
 - By doing so, you are positioning the ignition aid.
 8. Hold the measurement chamber with flange facing downward and blow out the particles in the measurement chamber with dry nitrogen.
 9. Push the polarity insert into the measurement chamber up to the mechanical stop.
 10. Insert the circlip correctly at the polarity insert.
 11. Do a visual inspection to ensure that the anode pin is central to the middle borehole of the polarity insert.
 - Max. permissible eccentricity = 0.5 mm
 12. Perform a leak test, if possible.
 - Leakage rate <math> < 10^{-9}</math> hPa l/s
 13. Install the magnetic unit.
 - Installing the magnetic unit is made more difficult due to the effect of magnetic force and the tendency for it to tilt easily.
 14. Fasten the hexagon head screw on the magnetic unit.
 15. Carefully install the electronic unit.
 - The male connector of the Pirani element must engage in the corresponding opening of the electronic unit.
 16. Push the electronic unit as far as the stop.
 17. Secure the grub screw on the side of the electronic unit.
 18. Calibrate the gauge.



9 Malfunctions



Warranty

Malfunctioning of the equipment as a direct result of contamination or wear, as well as wear parts (e.g. ignition aid) is not covered by the warranty.

Problem	Possible cause	Remedy
Continuous measuring signal < 0.5 V "Error low"	No supply	Switch on supply
Continuous measuring signal > 9.5 V "Error high"	Pirani measuring element defective (broken filament)	Replace the Pirani measuring element
	Electronic unit not fully inserted	Ensure that the electronic unit is fully inserted
Green LED lights up and identification indicates pure Pirani operation. (continuous measuring signal > 4.0 V) ("Pirani underrange")	Cold cathodes discharge has not ignited.	Wait until gas discharge ignites. (Complete failure is possible in the event of contamination with insulating layers.)
	Gauge was only activated at $p < 3 \times 10^{-9}$ hPa.	Allow a little gas to enter.
Continuous measuring signal > 5 V or display > 10^{-3} hPa, despite optimum vacuum	Pirani measuring circuit not calibrated, e.g. heavily contaminated	Calibrate Pirani measuring circuit or replace Pirani element if calibration is no longer possible
	Measurement of heavy gases	Conversion according to gas type dependency
	Intense exhaust gases in the cold cathodes measurement chamber	Clean the measurement chamber
Measuring signal unstable	Gauge contaminated	Clean the gauge

Tbl. 8: Malfunctions



10 Shipping

WARNING

Risk of poisoning from contaminated products

Where products that contain harmful substances are shipped for maintenance or repair purposes, the safety of service personnel is at risk.

- ▶ Comply with the instructions for safe shipping.

Shipping the product safely



Decontamination subject to charge

Pfeiffer Vacuum decontaminates products not clearly declared "Free of contamination" at your expense.

1. Do not ship microbiological, explosive or radioactively contaminated products.
2. Observe the shipping guidelines for the participating countries and transport companies.
3. Highlight any potential dangers on the outside of the packaging.
4. Download the declaration of contamination. ([Pfeiffer Vacuum Service](#)).
5. Always enclose a completed declaration of contamination.



11 Disposal

⚠ WARNING

Health hazard through poisoning from toxic contaminated components or devices

Toxic process media result in contamination of devices or parts of them. During maintenance work, there is a risk to health from contact with these poisonous substances. Illegal disposal of toxic substances causes environmental damage.

- ▶ Take suitable safety precautions and prevent health hazards or environmental pollution by toxic process media.
- ▶ Decontaminate affected parts before carrying out maintenance work.
- ▶ Wear protective equipment.

⚠ CAUTION

Health hazard caused by environmentally hazardous substances

Products, operating fluid, electric components, calibration gas residues (for example from test leaks) or similar pose health hazards.

- ▶ Dispose of the environmentally hazardous substances in accordance with local regulations.
- ▶ Dispose of calibration gas and test leaks in accordance with local regulations.

Dividing components

- ▶ After disassembly, divide the components into the following categories with regard to disposal:
 - contaminated components **that have** contact with process gases
 - non-contaminated components **that have no** contact with process gases

Disposal of contaminated components that have contact with process gases

1. Dispose of the substances in a safe manner in accordance with the locally applicable regulations if the process gases used were contaminated, e.g. radioactive, toxic, caustic or a microbiological manner.
2. Observe the environment and safety provisions of the respective country.

Disposal of components that do not have contact with process gases

1. Separate the components according to their type of material:
 - electronic components
 - electrical components
 - battery and rechargeable batteries
 - mechanical components
2. Recycle the components.
3. Dispose of the substances in a safe manner according to locally applicable regulations.
4. Observe the environment and safety provisions of the respective country.

12 Service solutions from Pfeiffer Vacuum

We offer first class service

Long vacuum component service life, coupled with low downtimes, are clear expectations that you have of us. We satisfy your needs with capable products and outstanding service.

We are consistently striving to perfect our core competence, service for vacuum components. And our service is far from over once you've purchased a product from Pfeiffer Vacuum. It often enough really just begins then. In proven Pfeiffer Vacuum quality, of course.

Our professional sales engineers and service technicians stand ready to provide hands-on support to you worldwide. Pfeiffer Vacuum offers a complete portfolio of service offerings, ranging from genuine spare parts right through to service agreements.

Take advantage of Pfeiffer Vacuum Service

Whether for preventative on-site service from our field service, fast replacement with as-new replacement products or repair in a Service Center close to you; you have various options for upholding your equipment availability. Detailed information and addresses can be found on our website in the Pfeiffer Vacuum Service section.

Advice on the optimum solution is available from your Pfeiffer Vacuum contact partner.

For quick and smooth handling of the service process, we recommend the following steps:



1. Download the current form templates.
 - Declaration of Service Request
 - Service Request
 - Declaration of Contamination



- a) Dismantle all accessories and keep them (all external mounted parts as valve, inlet screen, etc.).
 - b) Drain the operating fluid/lubricant as necessary.
 - c) Drain the cooling medium as necessary.
2. Fill out the service request and the declaration of contamination.



3. Send the forms via email, fax or post to your local Service Center.



4. You will receive a response from Pfeiffer Vacuum.

PFEIFFER VACUUM

Sending of contaminated products

No units will be accepted if they are contaminated with micro-biological, explosive or radioactive substances. If products are contaminated or if the declaration of contamination is missing, Pfeiffer Vacuum will contact the customer before starting maintenance. In addition, depending on the product and the level of contamination **additional decontamination costs** may be required.



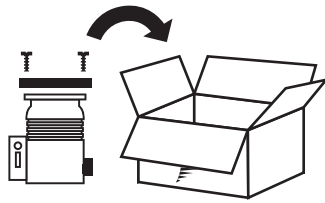

5. Prepare the product for transport in accordance with the details in the declaration of contamination.
 - a) Neutralize the product with nitrogen or dry air.
 - b) Close all openings with airtight blank flanges.
 - c) Seal the product in appropriate protective film.
 - d) Only pack the product in suitable, stable transport containers.
 - e) Observe the applicable transport conditions.

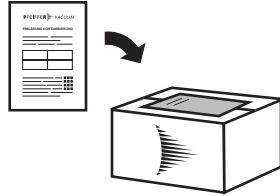

6. Affix the declaration of contamination to the **outside** of the packaging.

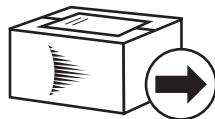

7. Then send your product to your local Service Center.

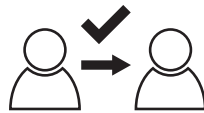

8. You will receive a confirmation message/a quotation from Pfeiffer Vacuum.

PFEIFFER VACUUM

For all service orders, our General Terms and Conditions of Sales and Supply and General Terms and Conditions of Repair and Maintenance apply to vacuum equipment and components.



13 Ordering information

13.1 Ordering parts

Ordering spare parts, accessories or optional components

- ▶ Always specify the following details when ordering spare parts, accessories or optional components:
 - all details according to the rating plate
 - description and order number according to the parts list

13.2 Spare parts

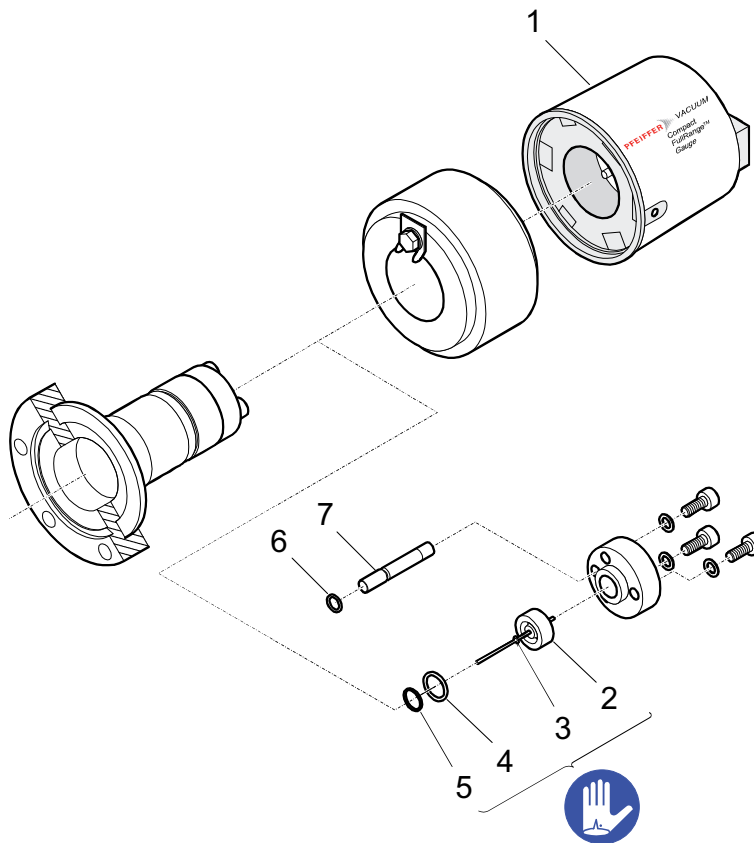

Fig. 15: Spare parts

- | | |
|---------------------------------|--------------------------------------|
| 1 Electronic unit | 5 Inner ring |
| 2 Anode, complete | 6 O-ring (FPM75, 3.69×1.78 mm) |
| 3 Ignition aid | 7 Pirani measuring element, complete |
| 4 O-ring (FPM75, 10.82×1.78 mm) | |

Description	Order number
Maintenance kit Item 3 (3×), item 4 (1×), item 5 (1×), item 6 (1×)	BN 846 239 -T
Repair kit, PKR 251, complete Item 2 (1×), item 3 (3×), item 4 (1×), item 5 (1×), item 6 (1×), item 7 (1×)	BN 846 238 -T
Repair kit, cold cathode only Item 2 (1×), item 3 (3×), item 4 (1×), item 5 (1×), item 6 (1×)	BN 846 252 -T
Ignition aid kit Item 3 (10×)	BN 845 995 -T
Mounting tool for ignition aid	BG 510 600
Pirani measuring element Item 7 (1×)	BN 846 056 -T



Description	Order number
Electronic unit PKR 251 Item 1 (1×)	PT 120 140 -T
Measurement system, complete (DN 25 ISO-KF)	BN 846 469 -T
Measurement system, complete (DN 40 ISO-KF)	BN 846 470 -T
Measurement system, complete (DN 40 CF-F)	BN 846 471 -T
Exchange gauge (DN 25 ISO-KF) ³⁾	PT R26 000 -A
Exchange gauge (DN 40 ISO-KF) ⁴⁾	PT R26 001 -A
Exchange gauge (DN 40 CF-F) ⁵⁾	PT R26 002 -A

13.3 Accessories



Installation and operation of accessories

Pfeiffer Vacuum offers a series of special, compatible accessories for its products.

- Information and ordering options for [ActiveLine accessories](#) can be found online.

Description	Order number
Measurement cable, 3 m	PT 448 250 -T
Measurement cable, 6 m	PT 448 251 -T
Measurement cable, 10 m	PT 448 252 -T
Mating connector	B 4707 283 MA
Magnetic shielding	PT 443 155 -X
Set of filter disks (10 x)	BN 846 250 -T

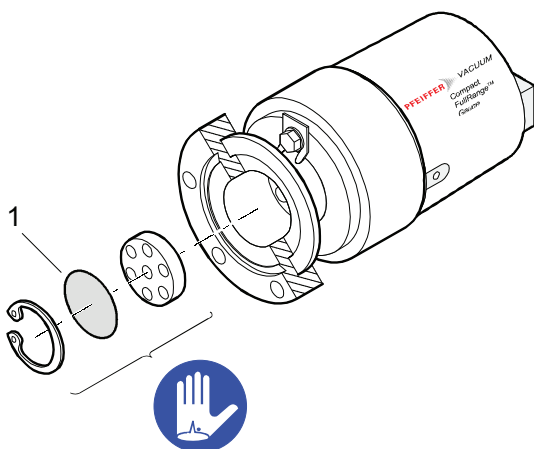

Fig. 16: Filter disk

1 Filter disk

- 3) You must return the defective gauge to Pfeiffer Vacuum.
- 4) You must return the defective gauge to Pfeiffer Vacuum.
- 5) You must return the defective gauge to Pfeiffer Vacuum.



14 Technical data and dimensions

Parameter	Value
Measuring range (air, N ₂)	5×10 ⁻⁹ up to 1000 hPa
Maximum pressure (absolute)	10000 hPa, limited to inert gases and temperatures < 55 °C
Measuring principle	Pirani/Cold cathode
Precision	approx. ±30 % within the range 1×10 ⁻⁸ up to 100 hPa
Repeatability	approx. ±5 % within the range 1×10 ⁻⁸ up to 100 hPa
Gauge calibration (HV) (Pirani measuring circuit)	at < 1×10 ⁻⁴ hPa (with simultaneous button press)
Gauge calibration (ATM) (Pirani measuring circuit)	at atmospheric pressure

Tbl. 9: Measuring and pressure values

Parameter	Value	
Output signal (measuring signal)	Voltage range	approx. 0 V to approx. +10.5 V
	Error signal	< 0.5 V (no supply) > 9.5 V (Pirani measuring element defective; broken filament)
	Relation voltage-pressure	logarithmic, rise 0.6 V / decade
Output impedance	2 × 10 Ω	
Load impedance (minimum load)	10 kΩ, short-circuit proof	
Response time	pressure-dependent	
	p > 10 ⁻⁶ hPa	approx. 10 ms
	p = 10 ⁻⁸ hPa	approx. 1 s
Gauge identification	Solely Pirani operation	Resistance 11.1 kΩ against supply earth
	Combined Pirani/cold cathodes operation	Resistance 9.1 kΩ against supply earth
	Conditions to be complied with in this regard: <ul style="list-style-type: none"> • The polarity of Pin 1 must always be positive against supply earth. • Measurements with constant current: Measurement current within the range 0.2 to 0.3 mA • Measurements with constant voltage: Measurement voltage within the range 2 to 3 V 	
Supply voltage	at gauge	15.0 to 30.0 V DC
	on the supply unit with max. cable length ⁶⁾	16.0 to 30.0 V DC
	Ripple	max. 1 V _{pp}
Operating voltage (in the measurement chamber)	≤ 3.3 kV	
Operating current (in the measurement chamber)	≤ 500 μA	
Power input	≤ 2 W	
Fuse (to be connected in series) ⁷⁾	≤ 1 AT	
Connection (electrical)	Hirschmann GO 6 (6-pin, pins)	
Measurement cable	5-pin, including shielding	
Cable length	max. 75 m (0.25 mm ² / conductor)	
	max. 100 m (0.34 mm ² / conductor)	
	max. 300 m (1.0 mm ² / conductor)	

6) The minimum voltage for the supply unit must be increased proportional to the cable length.

7) Pfeiffer Vacuum measuring and control equipment complies with this requirement.



Parameter	Value	
Earthing concept	(see chapter "Establishing the electrical connection", page 21)	
	Vacuum connection and signal ground	Connected with 10 kΩ (max. differential voltage with regard to safety ± 50 V, with regard to accuracy ± 10 V)
	Supply earth and signal earth	Channeled separately; differential measurement recommended for longer cable lengths (≥ 6 m)

Tbl. 10: Electrical data

Parameter	Value
Internal volume	approx. 20 cm ³
Weight	700 g (ISO-KF)
	950 g (CF-F)

Tbl. 11: Internal volume and weight

Parameter	Value
Relative humidity	max. 80 % for temperatures up to +31 °C, reducing to 50 % at +40 °C
Mounting orientation	Arbitrary
Use	Only in indoor areas
Installation altitude max.	2000 m MSL
Protection category	IP40

Tbl. 12: Ambient conditions

Parameter	Value
Operation	5 to 55 °C
Storage	-40 to +65 °C
Bake out	≤ 150 °C ⁸⁾

Tbl. 13: Temperatures

Parameter	Value
Flange	for DN 25: Stainless steel (1.4104)
	for DN 40: Stainless steel (1.4306)
Measurement chamber	Stainless steel (1.4104)
Insulating bushing	Ceramic (Al ₂ O ₃), glass
Internal seals	FPM75
Anode	Molybdenum (Mo)
Ignition aid	Stainless steel (1.4310)
Pirani measuring tube	Nickel (Ni), gold (Au)
Pirani filament	Tungsten (W)

Tbl. 14: Material against vacuum

8) Without electronic unit and magnetic shielding



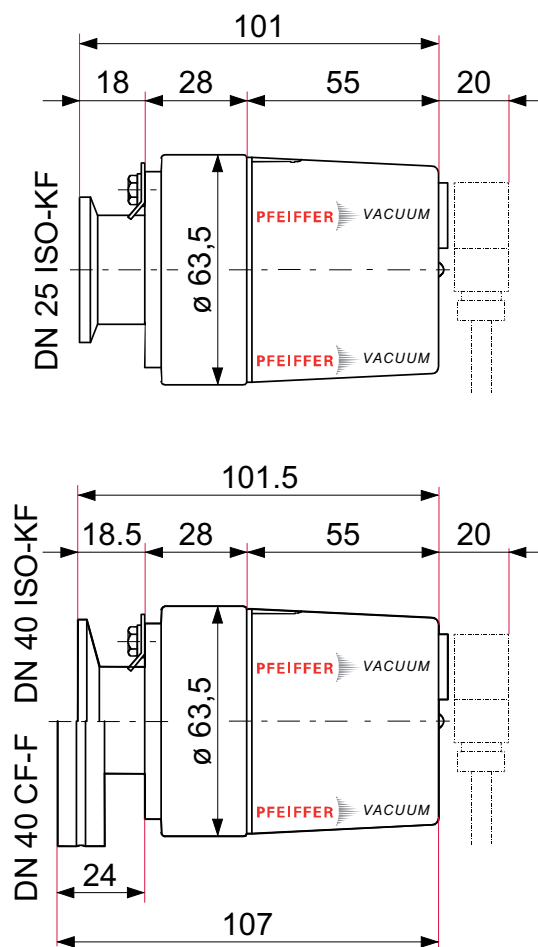

Fig. 17: Dimensions

Dimensions in mm.



15 Appendix

15.1 Units of pressure

Unit	mbar	bar	Pa	hPa	kPa	Torr / mm Hg
mbar	1	$1 \cdot 10^{-3}$	100	1	0.1	0.75
bar	1000	1	$1 \cdot 10^5$	1000	100	750
Pa	0.01	$1 \cdot 10^{-5}$	1	0.01	$1 \cdot 10^{-3}$	$7.5 \cdot 10^{-3}$
hPa	1	$1 \cdot 10^{-3}$	100	1	0.1	0.75
kPa	10	0.01	1000	10	1	7.5
Torr / mm Hg	1.33	$1.33 \cdot 10^{-3}$	133.32	1.33	0.133	1

1 Pa = 1 N/m²

Tbl. 15: Units of pressure and their conversion

15.2 Gas throughputs

Unit	mbar l/s	Pa m ³ /s	sccm	Torr l/s	atm cm ³ /s
mbar l/s	1	0.1	59.2	0.75	0.987
Pa m ³ /s	10	1	592	7.5	9.87
sccm	$1.69 \cdot 10^{-2}$	$1.69 \cdot 10^{-3}$	1	$1.27 \cdot 10^{-2}$	$1.67 \cdot 10^{-2}$
Torr l/s	1.33	0.133	78.9	1	1.32
atm cm ³ /s	1.01	0.101	59.8	0.76	1

Tbl. 16: Gas throughputs and their conversion





Intertek
3103457

ETL LISTED

The product PKR 251

- conforms to the UL standard
UL 61010-1.

- is certified to the CAN/CSA standard
CAN/CSA C22.2 No. 61010-1.



Declaration of conformity

We hereby declare that the product cited below satisfies all relevant provisions of the following **EU Directives**:

- **Electromagnetic compatibility 2014/30/EU**
- **Restriction of the use of certain hazardous substances 2011/65/EU**

**Pirani/cold cathode gauge
PKR 251**

Harmonized standards and applied national standards and specifications:

DIN EN 61000-6-2:2006-03
DIN EN 61000-6-3:2011-09
DIN EN 61010-1:2011-07
DIN EN 61326-1:2013-07

Signature:



(Dr. Ulrich von Hülsen)
Managing Director

Pfeiffer Vacuum GmbH
Berliner Straße 43
35614 Aßlar
Germany

Aßlar, 2019-04-10



VACUUM SOLUTIONS FROM A SINGLE SOURCE

Pfeiffer Vacuum stands for innovative and custom vacuum solutions worldwide, technological perfection, competent advice and reliable service.

COMPLETE RANGE OF PRODUCTS

From a single component to complex systems:

We are the only supplier of vacuum technology that provides a complete product portfolio.

COMPETENCE IN THEORY AND PRACTICE

Benefit from our know-how and our portfolio of training opportunities!

We support you with your plant layout and provide first-class on-site service worldwide.

ed. D - Date 1908 - P/N:BG5155BEN



Are you looking for a
perfect vacuum solution?
Please contact us

Pfeiffer Vacuum GmbH
Headquarters • Germany
T +49 6441 802-0
info@pfeiffer-vacuum.de

www.pfeiffer-vacuum.com

PFEIFFER  **VACUUM**

